

Right view
Scale: 1:1

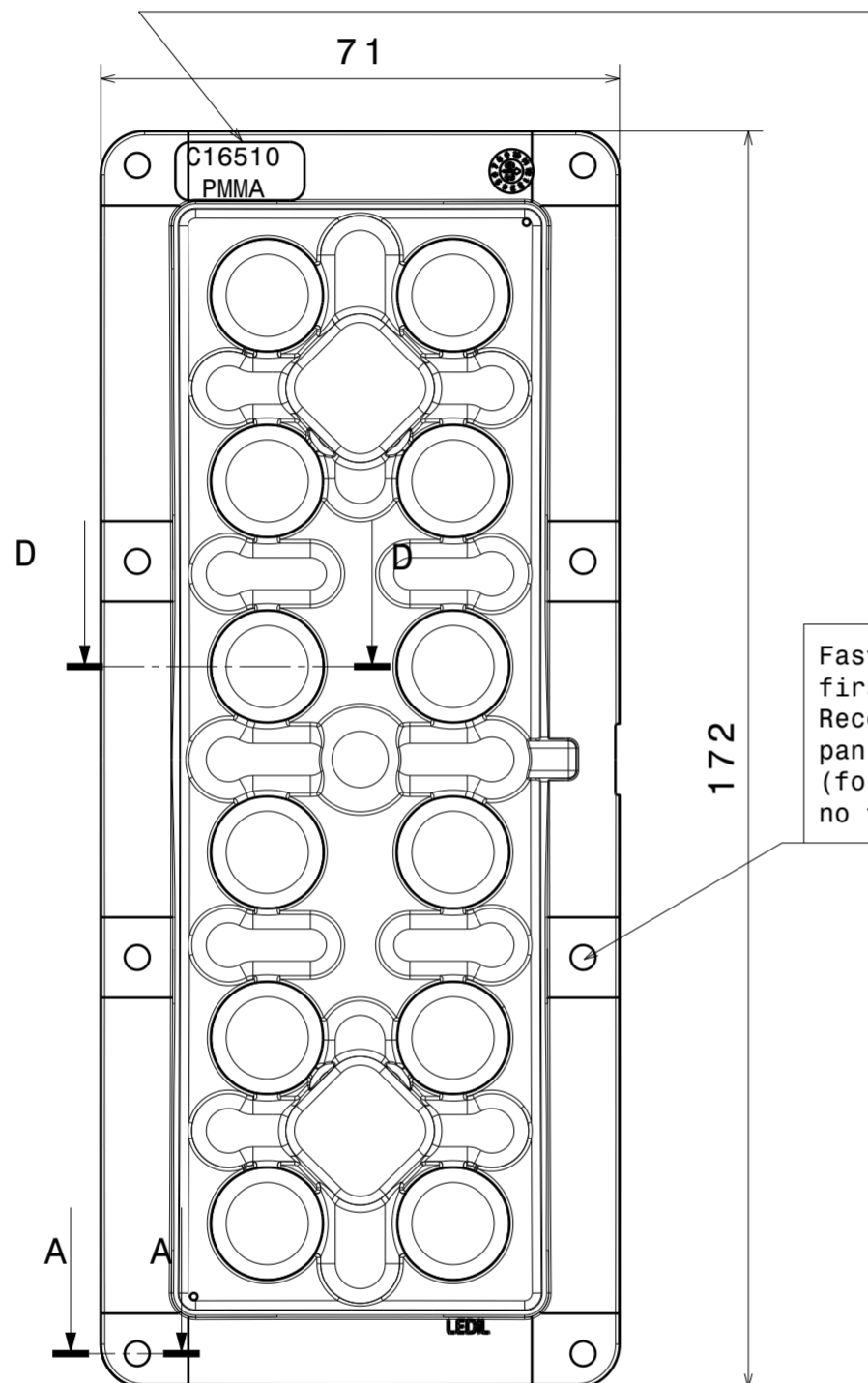

Front view
Scale: 1:1

Fasten middle screws first.
Recommended torque with pan head screw: 0.6Nm
(for 1.6mm thick PCB, no thermal pad)

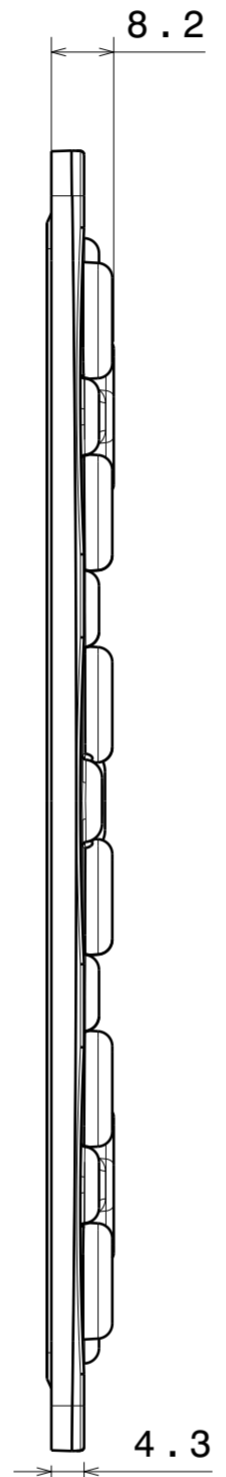

Left view
Scale: 1:1

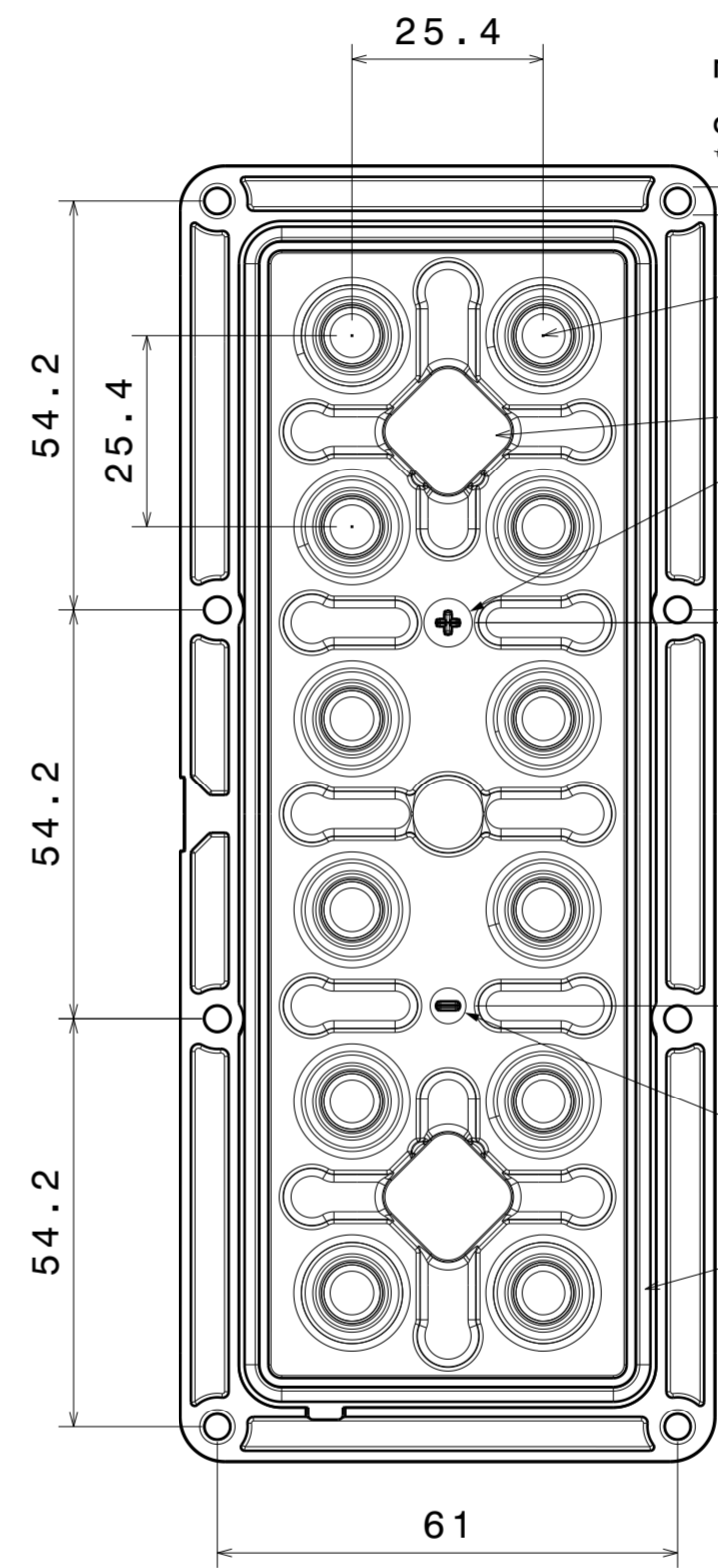

Rear view
Scale: 1:1

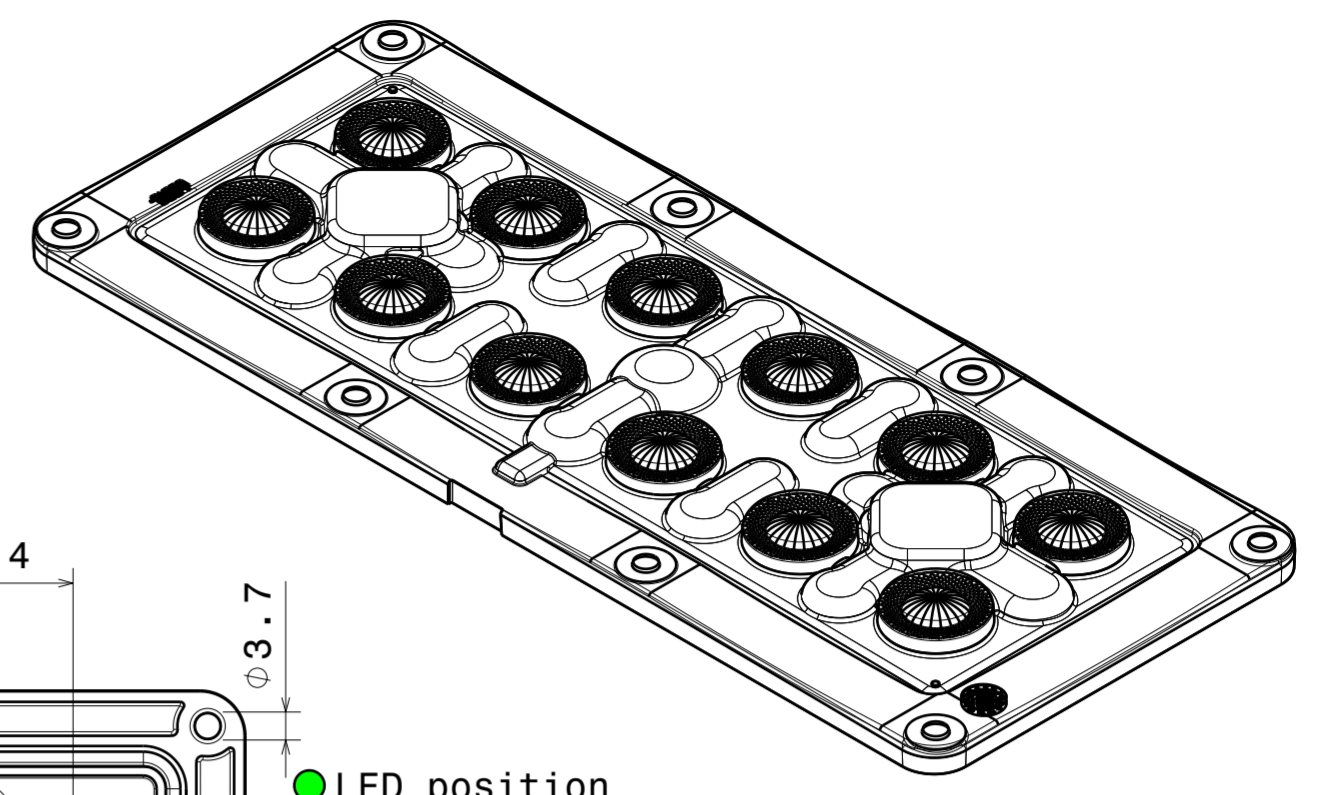

Isometric view
Scale: 1:1

LED position
Wire terminal location:
Pocket size 13.5x13.5x5.1mm.

Wiring:
PCB is fully sealed between the lens with silicone seal and the heatsink. Wiring needs to be done through the PCB and heat sink to maintain high IP rating.

Silicone seal is tested to work in LEDiL test assemblies. Customer is recommended to test the sealing in the end product due many variables, such as heat sink surface and possible chemical traces

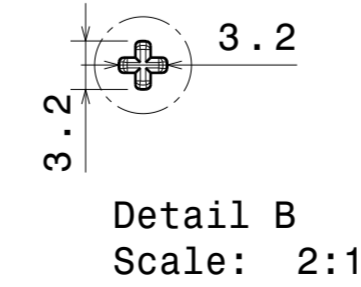
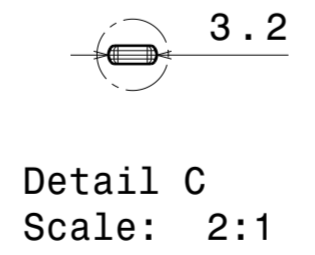
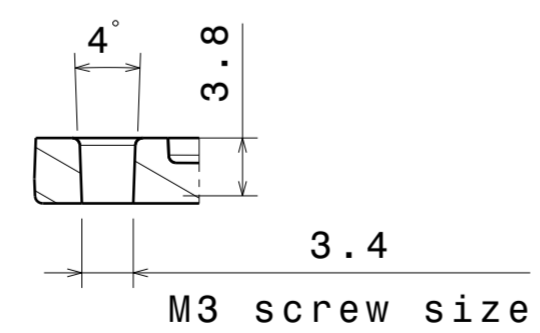
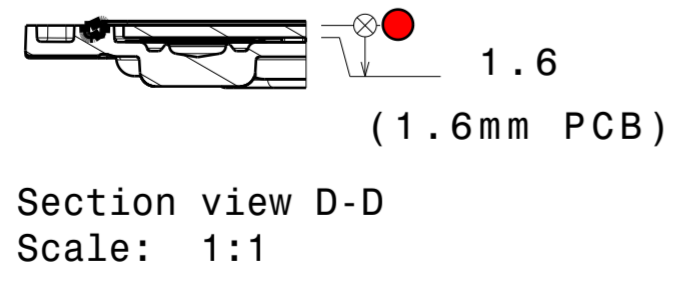

Notes

1	PCB or heatsink level.
2	LED location.
3	Ensure LED fitting from a product specific 3D model available from www.ledil.com .
4	See installation details in page 2.

PART	TYPE	MATERIAL	COLOR / COATING
CS16511_HB-IP-2X6-G2-W	HB-IP-2X6-W	PMMA 8N, Silicone seal	

MECHANICAL DRAWING		LEDiL®
PRODUCT		
CS16511_HB-IP-2X6-G2-W		This drawing is the property of LEDiL Oy. It may not be reproduced, copied or communicated without a written agreement with LEDiL Oy.
Tolerances if not otherwise shown According to DIN ISO 2768-1 Linear measures: Up to 30mm class M, otherwise class C. According to DIN ISO 2768-2 Form and position: class L		
SCALE	1:1	FIRST ANGLE PROJECTION:
WEIGHT	35 g	A2 SHEET 1/1