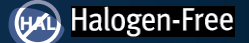

EPC2053 – Enhancement Mode Power Transistor

 $V_{DS}, 100\text{ V}$
 $R_{DS(on)}, 3.8\text{ m}\Omega$
 $I_D, 48\text{ A}$

Gallium Nitride's exceptionally high electron mobility and low temperature coefficient allows very low $R_{DS(on)}$, while its lateral device structure and majority carrier diode provide exceptionally low Q_G and zero Q_{RR} . The end result is a device that can handle tasks where very high switching frequency, and low on-time are beneficial as well as those where on-state losses dominate.

Maximum Ratings

PARAMETER		VALUE	UNIT
V_{DS}	Drain-to-Source Voltage (Continuous)	100	V
	Drain-to-Source Voltage (up to 10,000 5 ms pulses at 150°C)	120	
I_D	Continuous ($T_A = 25^\circ\text{C}$)	48	A
	Pulsed (25°C, $T_{PULSE} = 300\ \mu\text{s}$)	246	
V_{GS}	Gate-to-Source Voltage	6	V
	Gate-to-Source Voltage	-4	
T_J	Operating Temperature	-40 to 150	°C
T_{STG}	Storage Temperature	-40 to 150	

Thermal Characteristics

PARAMETER		TYP	UNIT
$R_{\theta JC}$	Thermal Resistance, Junction-to-Case	0.7	°C/W
$R_{\theta JB}$	Thermal Resistance, Junction-to-Board	4.7	
$R_{\theta JA}$	Thermal Resistance, Junction-to-Ambient (Note 1)	53	

Note 1: $R_{\theta JA}$ is determined with the device mounted on one square inch of copper pad, single layer 2 oz copper on FR4 board. See https://epc-co.com/epc/documents/product-training/Appnote_Thermal_Performance_of_eGaN_FETs.pdf for details.

Static Characteristics ($T_J = 25^\circ\text{C}$ unless otherwise stated)

PARAMETER		TEST CONDITIONS	MIN	TYP	MAX	UNIT
BV_{DSS}	Drain-to-Source Voltage	$V_{GS} = 0\text{ V}, I_D = 0.4\text{ mA}$	100			V
I_{DSS}	Drain-Source Leakage	$V_{DS} = 80\text{ V}, V_{GS} = 0\text{ V}, T_J = 25^\circ\text{C}$		0.07	0.3	mA
I_{GSS}	Gate-to-Source Forward Leakage	$V_{GS} = 5\text{ V}, T_J = 25^\circ\text{C}$		0.03	4	mA
		$V_{GS} = 5\text{ V}, T_J = 125^\circ\text{C}$		0.7	9	mA
	Gate-to-Source Reverse Leakage [#]	$V_{GS} = -4\text{ V}, T_J = 25^\circ\text{C}$		0.03	0.3	mA
$V_{GS(TH)}$	Gate Threshold Voltage	$V_{DS} = V_{GS}, I_D = 9\text{ mA}$	0.8	1.4	2.5	V
$R_{DS(on)}$	Drain-Source On Resistance	$V_{GS} = 5\text{ V}, I_D = 25\text{ A}$		3.1	3.8	mΩ
V_{SD}	Source-Drain Forward Voltage	$I_S = 0.5\text{ A}, V_{GS} = 0\text{ V}$		1.9		V

[#] Defined by design. Not subject to production test.

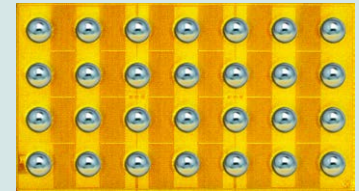

EPC2053 eGaN® FETs are supplied in passivated die form with solder bumps.
Die size: 3.5 mm x 2 mm

Applications

- 48 V Servers
- Lidar/Pulsed Power
- Isolated Power Supplies
- Point of Load Converters
- Class D Audio
- LED Lighting
- Low Inductance Motor Drive

Benefits

- Higher Switching Frequency – Lower switching losses and lower drive power
- Higher Efficiency – Lower conduction and switching losses, zero reverse recovery losses
- Ultra Small Footprint - Higher power density

Dynamic Characteristics ($T_j = 25^\circ\text{C}$ unless otherwise stated)

PARAMETER		TEST CONDITIONS	MIN	TYP	MAX	UNIT
C_{ISS}	Input Capacitance [#]	$V_{DS} = 50\text{ V}, V_{GS} = 0\text{ V}$		1579	1895	pF
C_{RSS}	Reverse Transfer Capacitance			10.4		
C_{OSS}	Output Capacitance [#]			642	963	
$C_{OSS(ER)}$	Effective Output Capacitance, Energy Related (Note 2)	$V_{DS} = 0\text{ to }50\text{ V}, V_{GS} = 0\text{ V}$		749		
$C_{OSS(TR)}$	Effective Output Capacitance, Time Related (Note 3)			903		
R_G	Gate Resistance			0.6		Ω
Q_G	Total Gate Charge [#]	$V_{DS} = 50\text{ V}, V_{GS} = 5\text{ V}, I_D = 25\text{ A}$		12.0	14.8	nC
Q_{GS}	Gate to Source Charge	$V_{DS} = 50\text{ V}, I_D = 25\text{ A}$		4.1		
Q_{GD}	Gate to Drain Charge			1.5		
$Q_{G(TH)}$	Gate Charge at Threshold			3.2		
Q_{OSS}	Output Charge [#]	$V_{GS} = 0\text{ V}, V_{DS} = 50\text{ V}$		45	68	
Q_{RR}	Source-Drain Recovery Charge			0		

Defined by design. Not subject to production test.

Note 2: $C_{OSS(ER)}$ is a fixed capacitance that gives the same stored energy as C_{OSS} while V_{DS} is rising from 0 to 50% BV_{DSS} .

Note 3: $C_{OSS(TR)}$ is a fixed capacitance that gives the same charging time as C_{OSS} while V_{DS} is rising from 0 to 50% BV_{DSS} .

Figure 1: Typical Output Characteristics at 25°C

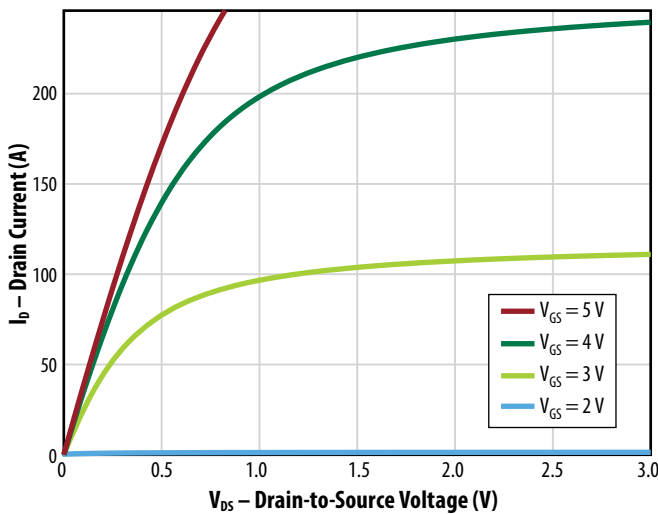

Figure 2: Transfer Characteristics

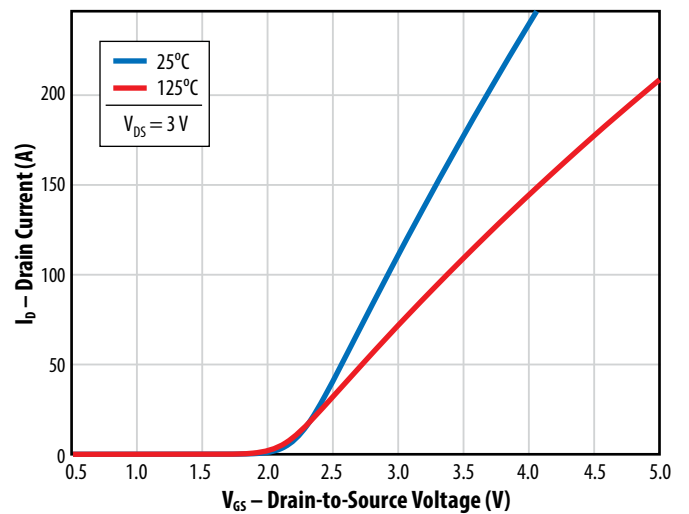

Figure 3: $R_{DS(on)}$ vs. V_{GS} for Various Currents

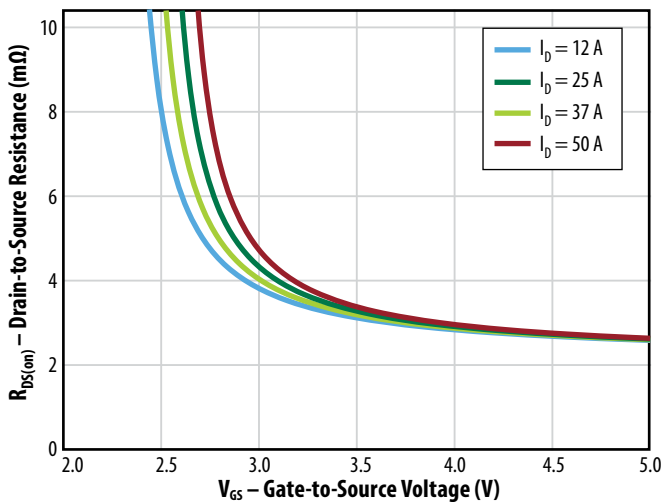

Figure 4: $R_{DS(on)}$ vs. V_{GS} for Various Temperatures

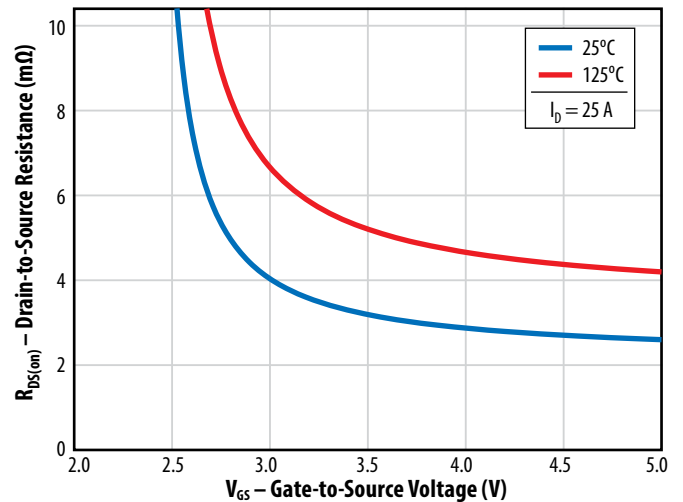

Figure 5a: Capacitance (Linear Scale)

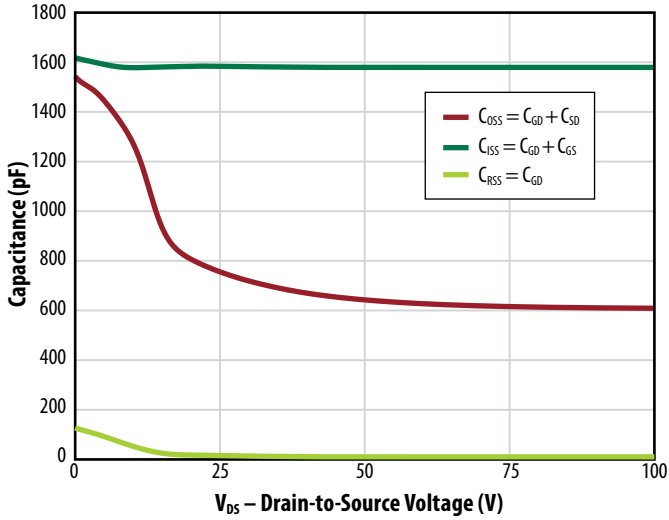

Figure 5b: Capacitance (Log Scale)

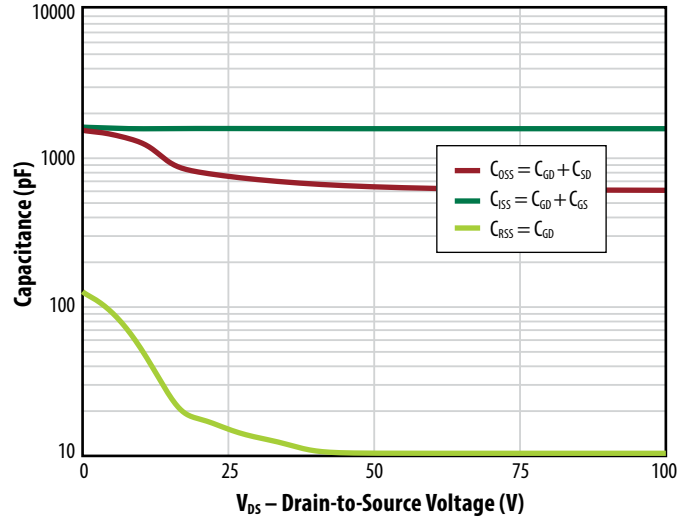

Figure 6: Output Charge and C_{OSS} Stored Energy

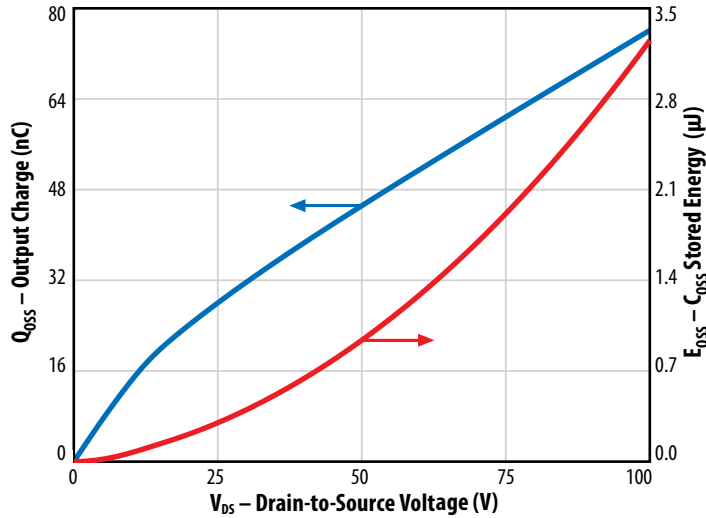

Figure 7: Gate Charge

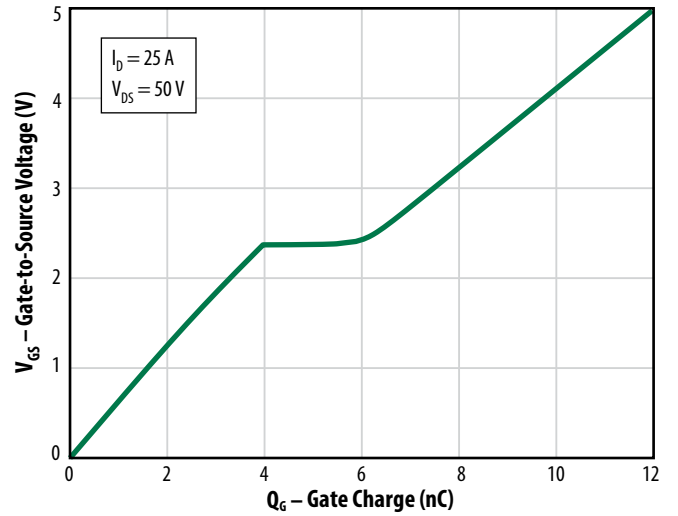

Figure 8: Reverse Drain-Source Characteristics

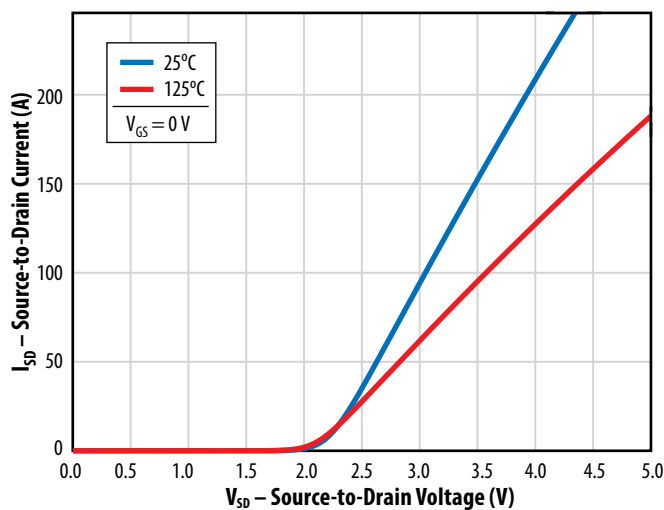

Figure 9: Normalized On-State Resistance vs. Temperature

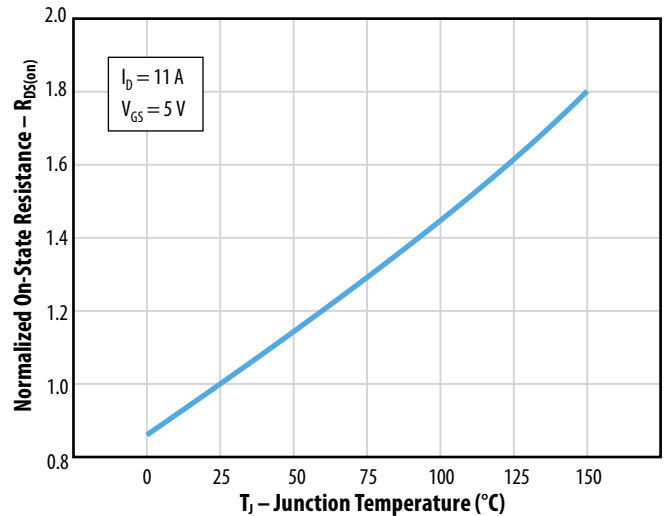

Figure 10: Normalized Threshold Voltage vs. Temperature

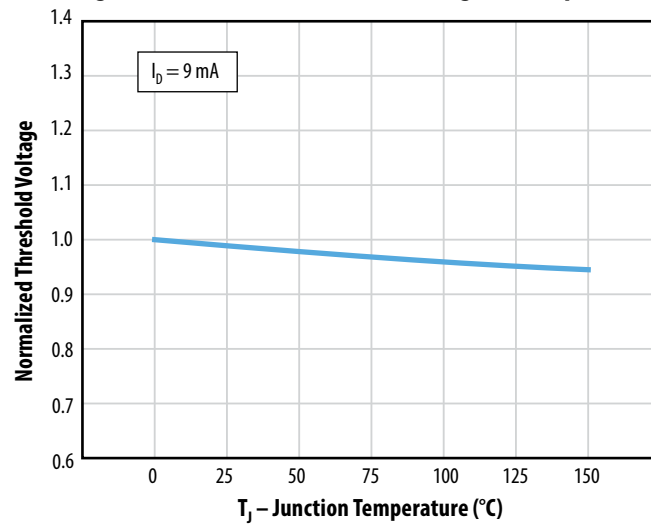

Figure 11: Transient Thermal Response Curves

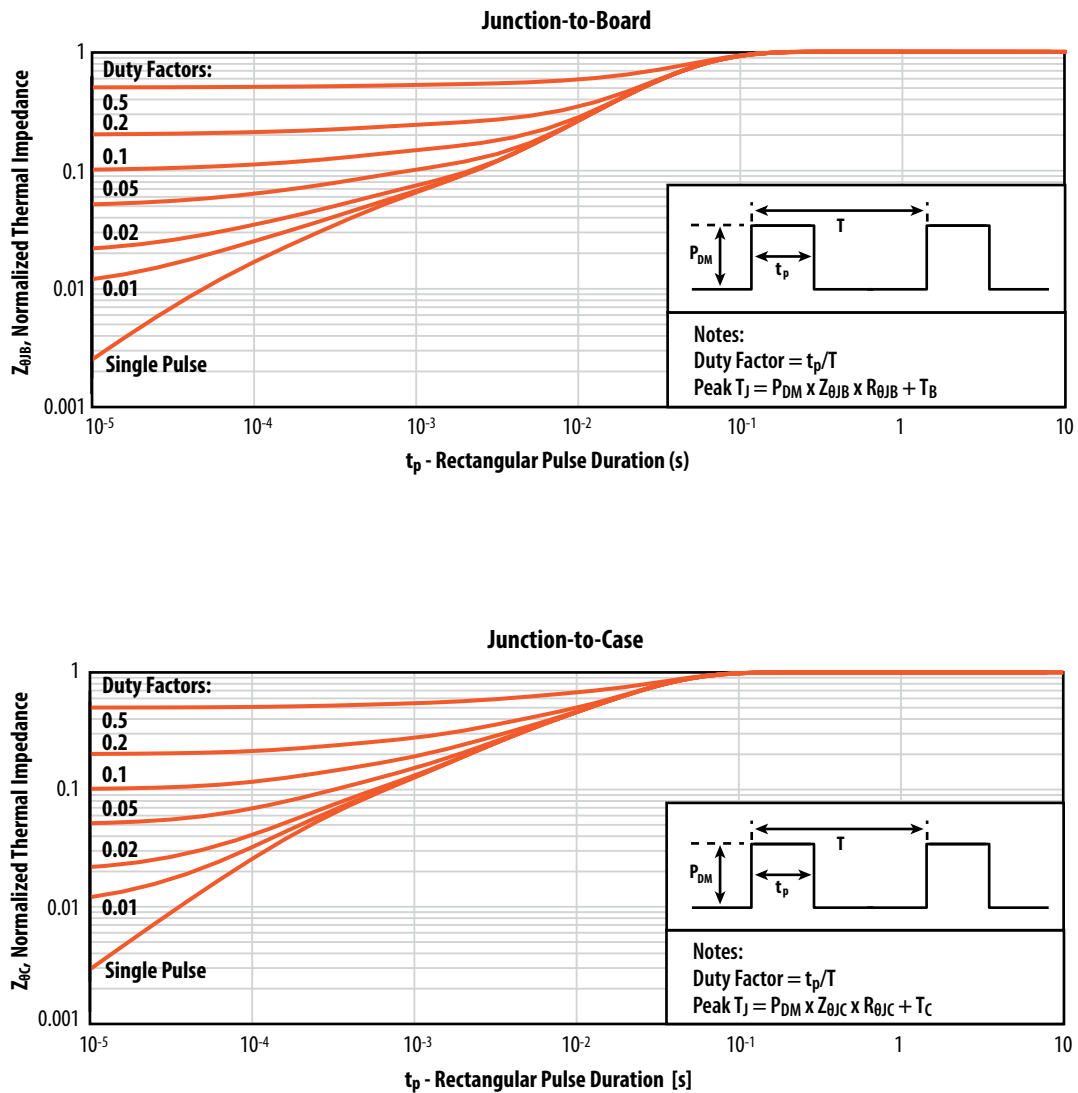
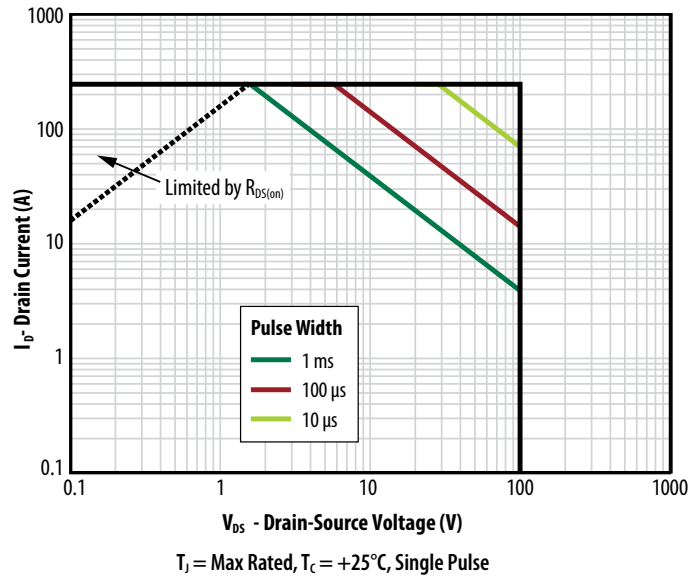
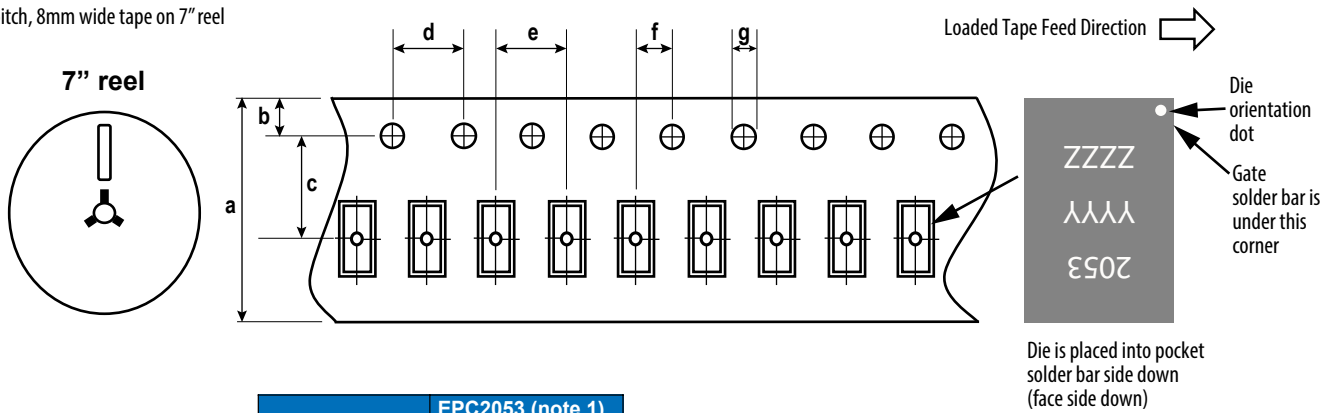

Figure 12: Safe Operating Area



TAPE AND REEL CONFIGURATION

4mm pitch, 8mm wide tape on 7" reel



Dimension (mm)	EPC2053 (note 1)		
	target	min	max
a	8.00	7.90	8.30
b	1.75	1.65	1.85
c (see note)	3.50	3.45	3.55
d	4.00	3.90	4.10
e	4.00	3.90	4.10
f (see note)	2.00	1.95	2.05
g	1.5	1.5	1.6

Note 1: MSL 1 (moisture sensitivity level 1) classified according to IPC/JEDEC industry standard.
 Note 2: Pocket position is relative to the sprocket hole measured as true position of the pocket, not the pocket hole.

DIE MARKINGS

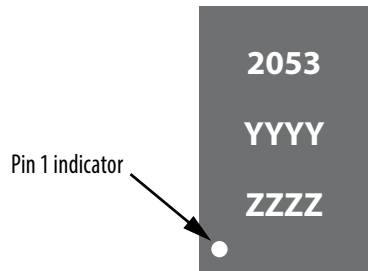

Part Number	Laser Markings		
	Part # Marking Line 1	Lot_Date Code Marking line 2	Lot_Date Code Marking Line 3
EPC2053	2053	YYYY	ZZZZ

DIE OUTLINE

Solder Bump View

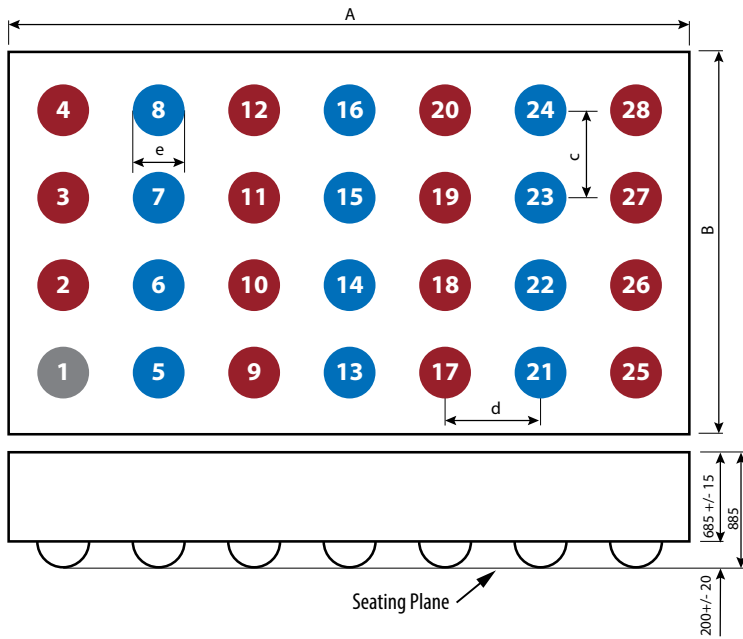

DIM	MICROMETERS		
	MIN	Nominal	MAX
A	3470	3500	3530
B	1920	1950	1980
c		450	
d		500	
e	238	264	290

Pad 1 is Gate;

Pads 2, 3, 4, 9, 10, 11, 12, 17, 18, 19, 20, 25, 26, 27, 28 are Source;

Pads 5, 6, 7, 8, 13, 14, 15, 16, 21, 22, 23, 24 are Drain.

Side View

RECOMMENDED LAND PATTERN (units in μm)

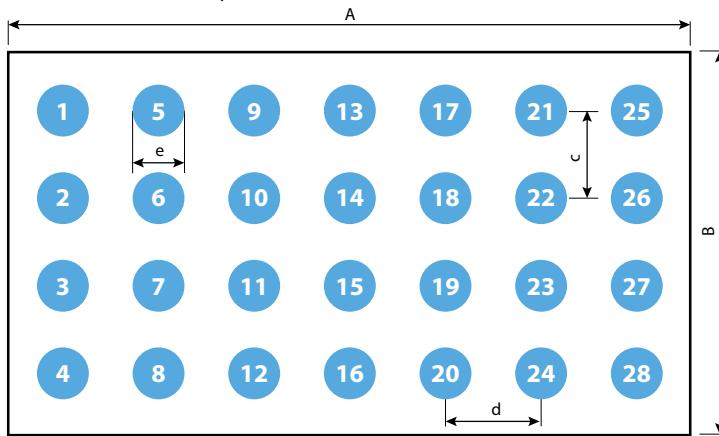

DIM	MICROMETERS
A	3500
B	1950
c	450
d	500
e	230

Pad 1 is Gate;

Pads 2, 3, 4, 9, 10, 11, 12, 17, 18, 19, 20, 25, 26, 27, 28 are Source;

Pads 5, 6, 7, 8, 13, 14, 15, 16, 21, 22, 23, 24 are Drain.

RECOMMENDED STENCIL DRAWING (measurements in μm)

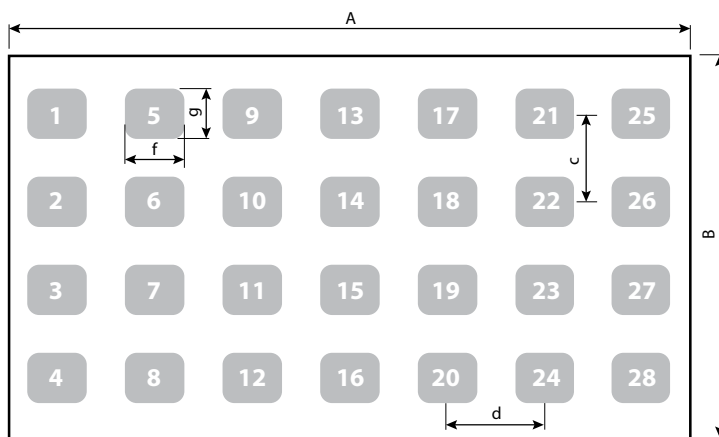

DIM	MICROMETERS
A	3500
B	1950
c	450
d	500
f	300
g	250

Recommended stencil should be 4 mil (100 μm) thick, must be laser cut, opening per drawing. The corner has a radius of R60.

Intended for use with SAC305 Type 4 solder, reference 88.5% metals content.

Additional assembly resources available at: <https://epc-co.com/epc/DesignSupport/AssemblyBasics.aspx>

Efficient Power Conversion Corporation (EPC) reserves the right to make changes without further notice to any products herein to improve reliability, function or design. EPC does not assume any liability arising out of the application or use of any product or circuit described herein; neither does it convey any license under its patent rights, nor the rights of others.

eGaN® is a registered trademark of Efficient Power Conversion Corporation.
EPC Patent Listing: epc-co.com/epc/AboutEPC/Patents.aspx

Information subject to change without notice.
Revised August, 2019