

Customer Information Sheet

DRAWING No.: M80-812XXXX

IF IN DOUBT - ASK

©

NOT TO SCALE

THIRD ANGLE PROJECTION

ALL DIMENSIONS IN mm

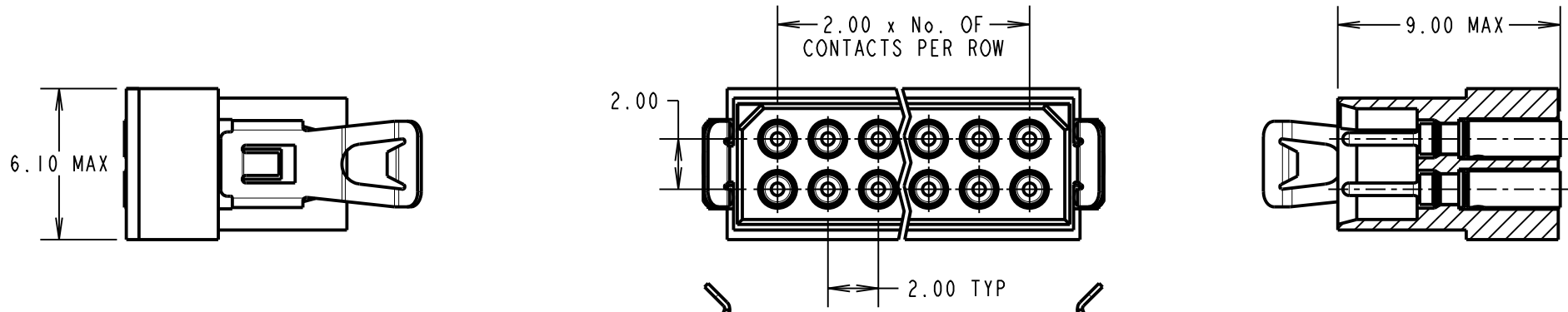

SPECIFICATIONS:

MATERIAL:
 MOULDING = GLASS-FILLED POLYAMIDE 46 UL94V-0, BLACK

CONTACTS = COPPER ALLOY
 LATCH = BERYLLIUM COPPER

FINISH:
 CONTACTS:
 05 = 0.25-0.30µm GOLD
 LATCH = 1.25µm NICKEL

ELECTRICAL:
 CURRENT RATING AT 25°C = 3.0A MAX
 CURRENT RATING AT 85°C = 2.2A MAX
 WORKING VOLTAGE = 800V AC/DC
 VOLTAGE PROOF = 1200V AC/DC

CONTACT RESISTANCE:
 INITIAL = 20mΩ MAX
 AFTER CONDITIONING = 25mΩ MAX

INSULATION RESISTANCE:
 INITIAL = 1,000MΩ MIN
 AFTER CONDITIONING = 100MΩ MIN

MECHANICAL:
 DURABILITY = 500 OPERATIONS

ENVIRONMENTAL:
 TEMPERATURE RANGE = -55°C TO +125°C

PACKING:
 BAG (CONTACTS AND MOULDINGS UN-ASSEMBLED)
 FOR COMPLETE SPECIFICATION, SEE COMPONENT SPECIFICATION C005XX (LATEST ISSUE)

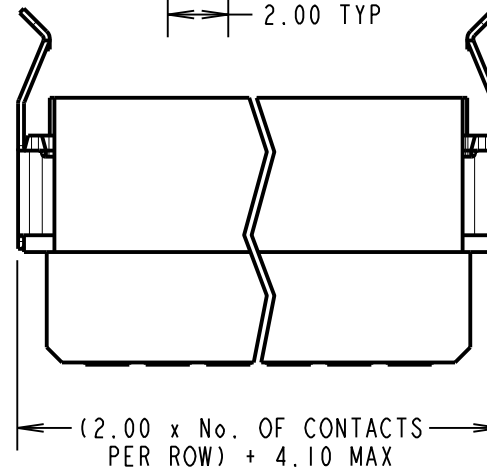
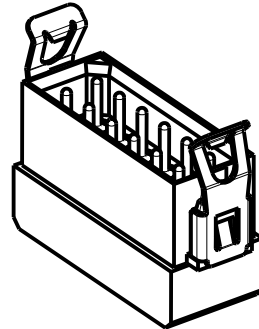

ORDER CODE:

M80-812XXXX

TOTAL No. OF CONTACTS
 04, 06, 08, 10, 12

FINISH
 05 - GOLD

NOTES:

1. RECOMMENDED WIRE TYPE = BS3G210 TYPE A, PTFE INSULATED, 24-28 AWG. MAX INSULATION DIAMETER = Ø1.10mm, STRIP WIRE BY 2.00mm. SEE COMPONENT SPECIF. C049XX FOR ALTERNATIVE RECOMMENDED WIRE TYPES.
2. RECOMMENDED HAND CRIMP TOOL = M22520/2-01 WITH POSITIONER T5747.
3. CONTACT INSERTION AND EXTRACTION TOOL = Z80-280.
4. REFER TO INSTRUCTION SHEET IS-01 FOR CRIMPING INSTRUCTIONS AND INSTRUCTION SHEET IS-25 FOR ASSEMBLY INSTRUCTIONS.
5. FOR EXTRA CONTACTS USE PART NUMBER M80-0410005.

MGP	10	03.08.21	30728
NAME	ISS.	DATE	CN/CO
APPROVED: MGP			
CHECKED: RTP			
DRAWN: W. J. BOURNE			
CUSTOMER REF.:			
ASSEMBLY DRG:			

HARWIN

www.harwin.com
 technical@harwin.com

THIS DRAWING AND ANY INFORMATION OR DESCRIPTIVE MATTER SET OUT HEREON ARE CONFIDENTIAL AND COPYRIGHT PROPERTY OF THE HARWIN GROUP AND MUST NOT BE DISCLOSED, LOANED, COPIED OR USED FOR MANUFACTURING, TENDERING OR FOR ANY OTHER PURPOSE WITHOUT THEIR WRITTEN PERMISSION.

TOLERANCES
 X. = ±1mm
 X.X = ±0.50mm
 X.XX = ±0.20mm
 X.XXX = ±0.01mm
 ANGLES = ±5°
 UNLESS STATED

MATERIAL:

SEE ABOVE

FINISH: SEE ABOVE

S/AREA: mm²

TITLE: DATAMATE 2mm PITCH
 CRIMP DIL LATCH PLUG ASSY
 SMALL BORE (24-28 AWG)

DRAWING NUMBER:

M80-812XXXX

SHT
 2 OF 2