

## Introduction

This user guide introduces the Atmel® SAMA5D4 Xplained Ultra evaluation kit (SAMA5D4-XULT) and describes the development and debugging capabilities for applications running on the Atmel | SMART SAMA5D4 ARM® Cortex™-A5-based embedded microprocessor unit (eMPU).

## Scope

This guide provides details on the SAMA5D4-XULT. It is made up of four main sections:

- [Section 1](#). describes the evaluation kit content and its main features.
- [Section 2](#). provides instructions to power up the SAMA5D4-XULT board.
- [Section 3](#). provides an overview of the SAMA5D4-XULT board.
- [Section 4](#). describes the SAMA5D4-XULT board components.

## Kit Contents

---

The SAMA5D4-XULT includes:

- Board
  - One SAMA5D4-XULT board
- Cables
  - One Micro-AB type USB cable
- A welcome letter

# Table of Contents

---

<b>Introduction</b> .....	1
<b>Scope</b> .....	1
<b>Kit Contents</b> .....	2
<b>Table of Contents</b> .....	3
<b>1. Evaluation Kit Specifications</b> .....	4
1.1 Electrostatic Warning .....	4
1.2 Power Supply Warning .....	4
<b>2. Power Source</b> .....	5
2.1 Power up the Board. ....	5
2.2 Sample Code and Technical Support .....	5
<b>3. Hardware Overview</b> .....	6
3.1 Introduction .....	6
3.2 Equipment List. ....	6
3.3 Board Features .....	7
<b>4. Board Components</b> .....	8
4.1 Board Overview. ....	8
4.2 Function Blocks. ....	9
4.3 PIO Usage and Interface Connectors .....	41
4.4 SAMA5D4-XULT Board Schematics .....	57
<b>5. Revision History</b> .....	72

# 1. Evaluation Kit Specifications

Table 1-1. Evaluation Kit Specifications

Characteristic		Specifications
Board		SAMA5D4-XULT
Board supply voltage		USB powered, 5VDC from optional jack connector or from "Arduino shield"
Temperature	Operating	0°C to +70°C
	Storage	-40°C to +85°C
Relative Humidity		0 to 90% (non-condensing)
Dimensions: Main board		135 × 88 × 20 mm
RoHS status		Compliant
Board Identification		SAMA5D4-XULT

## 1.1 Electrostatic Warning



### ESD-Sensitive Electronic Equipment!

The evaluation kit is shipped in a protective anti-static package. The board system must not be subject to high electrostatic potentials.



We strongly recommend using a grounding strap or similar ESD protective device when handling the board in hostile ESD environments (offices with synthetic carpet, for example). Avoid touching the component pins or any other metallic element on the board.

## 1.2 Power Supply Warning



### Hardware Power Supply Limitation

Using a power adapter greater than 5Vcc (e.g. the 12Vcc power adapters from other kits such as Arduino kits) may damage the board.



### Hardware Power Budget

Using the USB as the main power source (max. 500 mA) is acceptable only with the use of the on-board peripherals and low-power LCD extension.

When external peripheral or add-on boards need to be powered, we recommend the use of an external power adapter connected to the J4 DC jack (can provide up to 1.2A on the 3.3V node).

## 2. Power Source

Several options are available to power up the SAMA5D4-XULT board.

The board can be:

- USB-powered through the USB Micro-AB connector (J11 - default configuration).
- Powered through an external AC-to-DC adapter connected via a 2.1 mm center-positive plug into the optional power jack of the board (J4). The recommended output voltage range of the power adapter is 5V at 2A.
- Powered through the "Arduino" shield.
- Powered through the USB Micro-AB connector on the Atmel Embedded Debugger (EDBG) interface (J20).



**Unlike Arduino Uno boards, the SAMA5D4-XULT board runs at 3.3V. The maximum voltage that the I/O pins can tolerate is 3.3V. Providing higher voltages (e.g. 5V) to an I/O pin could damage the board.**

### 2.1 Power up the Board

Unpack the board, taking care to avoid electrostatic discharge. Connect the USB Micro-AB cable to the connector (J11). Then connect the other end of the cable to a free USB port of your PC.

**Table 2-1. Electrical Characteristics**

Electrical Parameter	Values
Input voltage	5 VCC
Maximum Input voltage (limits)	6 VCC
Max DC 3v3 current available	1.2A
I/O Voltage	3.3V only

### 2.2 Sample Code and Technical Support

After boot up, you can run some sample code or your own application on the development kit. You can download sample code and get technical support from the [Atmel website](#).

Linux software and demos can be found on the website [Linux4SAM](#).

## 3. Hardware Overview

### 3.1 Introduction

The Atmel SAMA5D4-XULT is a fully-featured evaluation platform for the Atmel | SMART SAMA5D4 series ARM-based embedded microprocessor units (eMPU). It allows users to extensively evaluate, prototype and create application-specific designs.

### 3.2 Equipment List

The SAMA5D4-XULT board is based on the integration of an ARM Cortex<sup>®</sup>-A5-based microprocessor with external memory, one Ethernet physical layer transceiver, two SD/MMC interfaces, two host USB ports and one device USB port, one 24-bit RGB LCD and HDMI interface and debug interfaces.

Seven headers, compatible with Arduino R3 (Uno, Due) and two Xplained headers are available for various shield connections.

### 3.3 Board Features

Table 3-1. Board Specifications

Characteristics	Specifications	
Dimensions (L x W x H)	135 x 88 x 20 mm	
Processor	SAMA5D44 ( 361-ball BGA package), 16x16 mm body, pitch 0.8 mm	
Oscillators	MPU, EDBG: 12 MHz quartz RTC: 32.768 KHz PHY: 25 MHz	
Main Memory	2 x DDR2 2 Gb 16 Meg x 16 x 8 banks (total 4Gbit = 512 MB) 1 x SLC NAND Flash 4 Gb 8-bit data (total 4Gbit = 512 MB)	
Accessory memories	One optional Serial EEPROM SPI One EEPROM with Mac Address and Serial Number	
SD/MMC	One 4-bit SD card connector One 4-bit Micro-SD card connector	
USB	Two USB Hosts with power switch One Micro-AB USB device	
Display	One LCD interface connector, LCD TFT Controller with overlay, alpha-blending, rotation, scaling and color space conversion	
	One HDMI interface and connector	
Ethernet	One Ethernet PHY (RMII 10/100MHz)	
Debug port	One JTAG interface connector	One serial DBGU interface (3v3 level)
	One EDBG interface	
Expansion connector	Arduino R3 compatible set of connectors	XPRO set of connectors
Board supply voltage	5V from USB, power jack, and Arduino shield On-board power regulation by PMIC	
Battery	On-board battery socket	
User interface	Reset, Wake-up and free user push button	One red user/power LED and one blue user LED

## 4. Board Components

### 4.1 Board Overview

The fully-featured SAMA5D4-XULT board integrates multiple peripherals and interface connectors, as shown in Figure 4-1.

Figure 4-1. SAMA5D4-XULT Board Overview

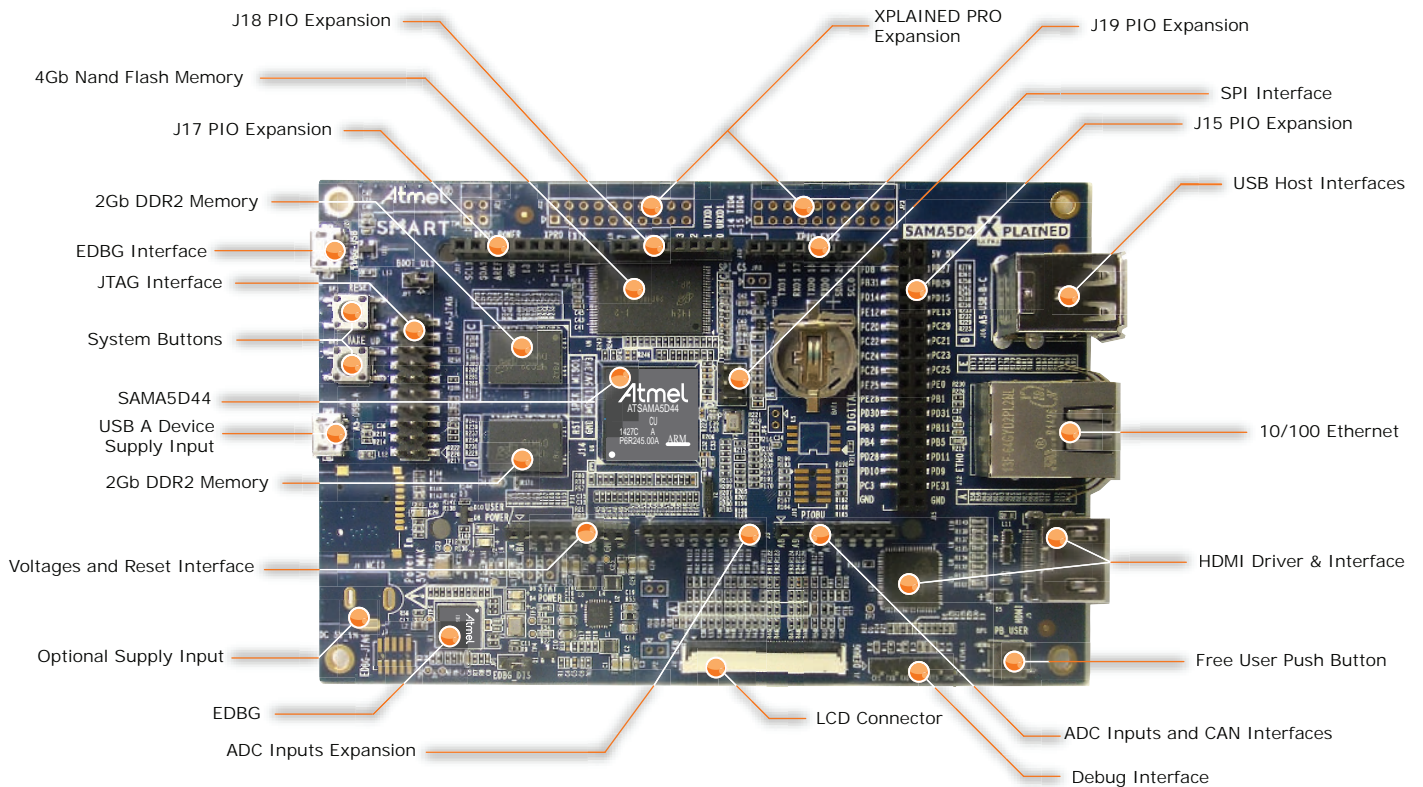



Table 4-1 describes the interface connectors on the SAMA5D4-XULT.

**Table 4-1. SAMA5D4-XULT Board Interface Connectors**

Connector	Interfaces to
J4	Main power supply
J11	USB A Device. Supports USB device using a type Micro-AB connector
J16	USB Host B and C. Supports USB host using a stacked type A connector
J1	Serial DBGU (3.3V level)
J13	JTAG, 20 pin IDC connector
J20	EDBG USB connector
J9	Micro-SD connector
J24	SD/MMC connector
J12	Ethernet ETH0
J2	Expansion connector with all LCD controller signals for display module connection (QTouch®, TFT LCD display with touchscreen and backlight)
J5	HDMI connector type A
BAT1	CR1225 Battery holder
J6, J7, J8, J14, J15, J17, J18, J19	Expansion connectors with Arduino R3 compatible PIO signals
J21, J22, J23	Expansion connectors Xplained
J3	JTAG EDBG (not populated)
J10	PIOBU extension (not populated)

## 4.2 Function Blocks

### 4.2.1 Processor

The SAMA5D4 series is a high-performance, power-efficient ARM Cortex-A5 processor MPU capable of running up to 528 MHz. It integrates the ARM NEON™ SIMD engine for accelerated signal processing, multimedia and graphics as well as a 128 KB L2-Cache for high system performance. The device features the ARM TrustZone® enabling a strong security perimeter for critical software, as well as several hardware security features. The device also features advanced user interface and connectivity peripherals.

The SAMA5D4 features an internal multi-layer bus architecture associated with 32 DMA channels to sustain the high bandwidth required by the processor and the high-speed peripherals. The device supports DDR2/LPDDR/LPDDR2 and SLC/MLC NAND Flash memory with 24-bit ECC.

The comprehensive peripheral set includes a 720p hardware video decoder, an LCD controller with overlays for hardware-accelerated image composition, a resistive touch screen function, and a CMOS sensor interface. Connectivity peripherals include a dual 10/100 Ethernet MAC with IEEE1588, three HS USB ports, UARTs, SPIs and I2Cs.

Security features include an "on-the-fly" encryption-decryption process from the external DDR memory, tamper detection pins, secure storage of critical data, an integrity check monitor (ICM) to detect modification of the memory contents, and a secure boot. The product also includes a dedicated coprocessor for public key cryptography such as RSA and elliptic curves algorithms (ECC), as well as AES, 3DES, hashing function and TRNG. These features permit to protect the system against counterfeiting, to safeguard sensitive data, authenticate safe program or secure external data transfers.

The SAMA5D4 series is optimized for control panel/HMI applications needing video playback and applications that require high levels of connectivity in the industrial and consumer market. Its security features makes the SAMA5D4 well suited for secure gateways or for the IOT.

## 4.2.2 Power Supply Topology and Power Distribution

### 4.2.2.1 Power Lines

- 1.8V VDDCORE: SAMA5D4 series embeds an internal regulator powered by VDDCORE and generating 1.2V VCCCOREOUT. SAMA5D44 requires a 1.8V voltage (in the range from 1.70V to 1.88V) for VDDCORE, 1.2V VCCCOREOUT must be connected to VCCCORE, VDDUTMIC and VDDPLLA.
- 1.8V VDDIODDR: SAMA5D4 series requires a 1.8V voltage (in the range of 1.75V-1.85V) for VDDIODDR. Only one 300 mA regulator can provide VDDIODDR and VDDCORE.
- 2.0V VDDBU: SAMA5D4 series requires a 2.0V voltage (in the range of 1.96V-2.04V) for VDDBU.
- 3.3V VDDIOP: SAMA5D4 series requires a 3.3V voltage (in the range of 3.15V-3.45V) for VDDIOP, VDDOSC, VDDIOM, VDDANA and VDDUTMII.
- 2.5V VDDFUSE: SAMA5D4 series requires a 2.5V voltage (in the range of 2.25V-2.75V) for fuse writing operations.

### 4.2.2.2 Power-up Considerations

To ensure reliable operation of the device, power-up must follow the sequence below:

1. Set VDDBU. Do not remove VDDBU in any case.
2. Set VDDIO/VDDANA.
3. Set VDDCORE/VDDPLL
4. Other power supplies are optional and may be set if required by the application.



**WARNING**

**This power-up sequence must be respected for reliable operation.**

---

### 4.2.2.3 Power-down Considerations

VDDBU must never be removed when other supplies are present.

#### 4.2.2.4 SAMA5D44 Power Supplies Summary

**Table 4-2. SAMA5D44 Power Supplies**

Name	Voltage Range, Nominal	Associated Ground	Powers
VDDCORE	1.62–1.98V, 1.8V	GNDCORE	Regulator that generates core power supply on VCCCORE 10 µF decoupling capacitor is to be connected to VCCCORE MUST BE ESTABLISHED AFTER VDDIOP OR AT THE SAME TIME
VCCCORE	1.1–1.32V, 1.2V	GNDCORE	Core
VDDIODDR	1.70–1.90V, 1.8V	GNDIODDR	DDR2 Interface I/O lines
	1.14–1.30V, 1.2V		LP-DDR2 Interface I/O lines
VDDIOM	1.65–1.95V, 1.8V 3.0–3.6V, 3.3V	GNDIOM	NAND and HSMC Interface I/O lines
VDDIOP <sup>(1)</sup>	3.0–3.6V, 3.3V	GNDIOP	Peripherals I/O lines MUST BE ESTABLISHED PRIOR TO VDDCORE
VDDBU	1.88V–2.12V, 2V	GNDBU	Slow Clock oscillator, the internal 64 kHz RC and a part of the System Controller MUST BE ESTABLISHED FIRST
VDDUTMIC	1.1–1.32V, 1.2V	GNDUTMI	USB device and host UTMI+ core and the UTMI PLL MUST be connected to VCCCORE
VDDUTMII	3.0–3.6V, 3.3V	GNDUTMI	USB device and host UTMI+ interface
VDDPLLA	1.1–1.32V, 1.2V	GNDPLL	PLLA cell MUST be connected to VCCCORE
VDDOSC	3.0V–3.6V	GNDOSC	Main Oscillator cell
VDDANA <sup>(1)</sup>	3.0–3.6V, 3.3V	GNDANA	Analog parts MUST be connected to VDDIOP with filtering
VDDFUSE	2.25–2.75V, 2.5V	GNDFUSE	Fuse box for programming VDDFUSE must be 2.5V or 0V and must not be left floating

Notes: 1. Both must rise at the same time due to internal constraints.



board in most applications. It is important to note that when the USB supply is used, the USB Host ports do not function. If USB Host ports are required for the application, it is recommended that a DC supply be used.

Figure 4-3 provides the schematics of power options.

**Figure 4-3. Input Powering Scheme Option**

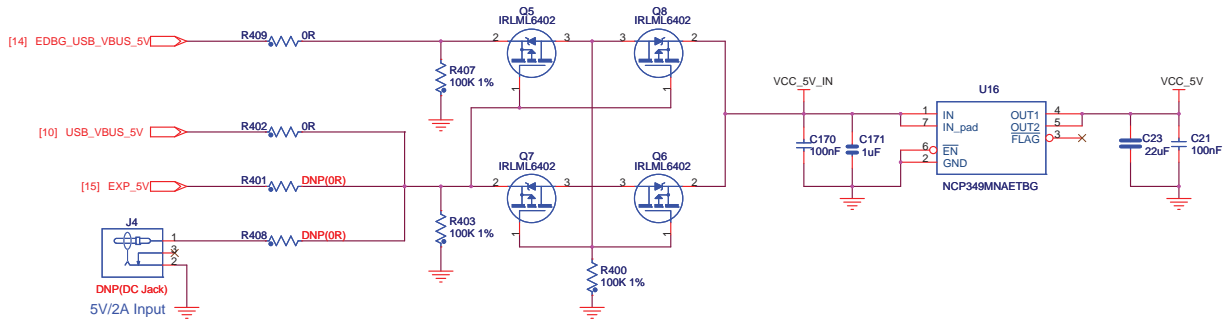

Note: USB-powered operation eliminates additional wires and batteries. It is the preferred mode of operation for any project that requires only a 5V source at up to 500 mA.

#### 4.2.2.7 Wall Supply Source

A wall supply can be used to provide power to the board. A regulated 5V DC supply of at least 2A is required. If USB ports and expansion headers are used, a rating of 3A is preferred. A 2.1 mm plug with a center-hot configuration is required.

If the USB host ports or expansion board "Arduino shields" are used, additional current is necessary.

If the DC load required is greater than 500 mA per port, a higher current supply must be used.

#### 4.2.2.8 Backup Power Supply

The SAMA5D4-XULT board requires a battery (3V Lithium Battery type CR1225 or equivalent) in order to permanently power the backup part of the SAMA5D4 device (refer to SAMA5D4 Series datasheet).

To avoid losing data and saved registers, the board must be powered on when replacing the battery.

**Figure 4-4. VBAT Powering Scheme Option**

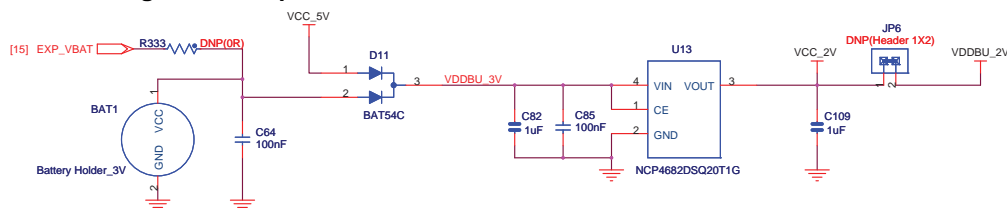

#### 4.2.2.9 Power Supply Control

In the ACT8865, three DCDCs (1.8V, 1.2V, 3.3V) and two LDO outputs are available.

All ACT8865 outputs can be controlled by the TWI interface through software.

The three DCDCs outputs can be enabled or disabled by the SAMA5D44 SHDN output:

- SHDN=0: The DCDCs output is disabled.
- SHDN=1: The DCDCs output is enabled.

Two push buttons are also available:

- Wakeup push button: When pressed, the ACT8865 power outputs are restarted if the ACT8865 is in shutdown mode.

- Reset push button: When pressed, the ACT8865 transfers the reset signal to NRST\_3V3, and then to NRST\_2V for the MPU by using a resistor divider.

### 4.2.3 Reset Circuitry

The reset sources for SAMA5D4-XULT board are:

- Power-on reset from the Power Management Unit (PMIC)
- Push button reset BP3
- External reset from "Arduino" connectors
- JTAG or EDBG reset from an in-circuit emulator

Figure 4-5. Reset/Wakeup and Shutdown Control

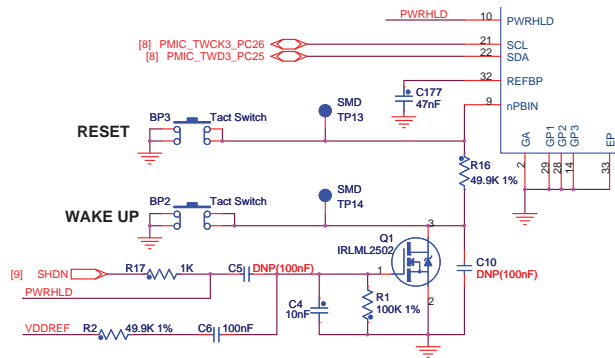

### 4.2.4 Clock Circuitry

The SAMA5D4-XULT board includes four clock sources:

- Two clocks are alternatives for the SAMA5D44 processor (12 MHz, 32 KHz)
- One crystal oscillator used for the Ethernet RMII chip (25 MHz)
- One crystal oscillator used for the EDBG (12 MHz)

Figure 4-6. Clock Circuitry

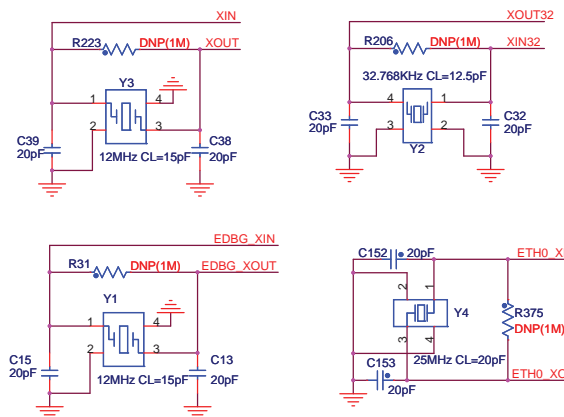

## 4.2.5 Memory

### 4.2.5.1 Memory Organization

The SAMA5D4 features a DDR/SDR memory interface and an External Bus Interface (EBI) to permit interfacing to a wide range of external memories and to almost any kind of parallel peripheral.

This section describes the memory devices that equip the SAMA5D4-XULT board.

#### 4.2.5.2 DDR2/SDRAM

- Two DDR2/SDRAM (MT47H128M16 - 2Gb - 16 Meg x 16 x 8 banks) are used as main system memory. The board provides 4 Gb on-board, soldered DDR2 (double data rate) SDRAM. The memory bus is 32 bits wide and operates with a frequency of up to 176 MHz.

Figure 4-7. DDR2

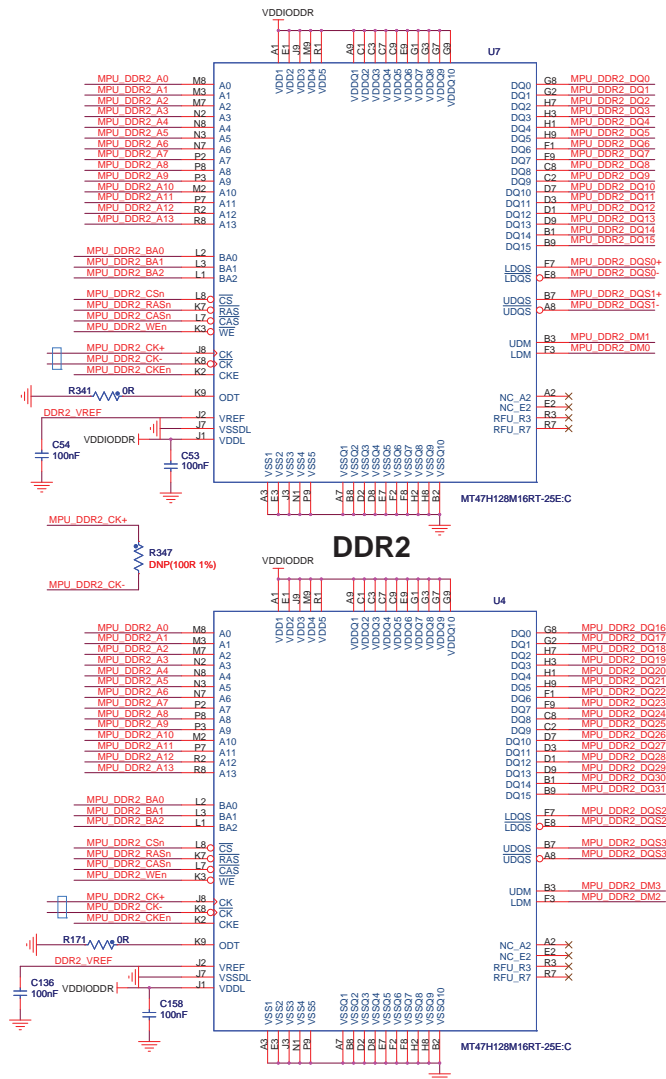

### 4.2.5.3 DDR\_CALP and DDR\_CALN Analog Inputs

Two specific analog inputs, DDR\_CALP and DDR\_CALN, are used to calibrate all DDR I/Os.

Figure 4-8. DDR\_CALP and DDR\_CALN Analog Inputs

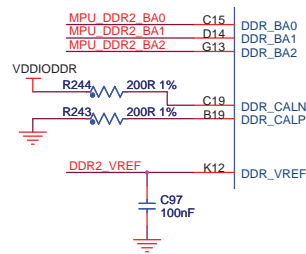

Table 4-3. DDR\_CALN & DDR\_CALP

	CALP Pull-down	CALN Pull-up
DDR2	200 Ohm	200 Ohm
LPDDR2	240 Ohm	240 Ohm

### 4.2.5.4 NAND Flash

One 512 MB NAND Flash is connected to the processor.

Figure 4-9. NAND Flash

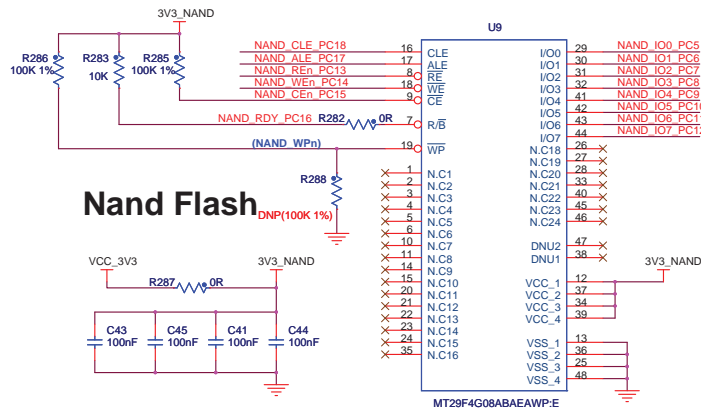

### 4.2.5.5 CS Disable

The SAMA5D44 device boots according to the following sequence:

1. the SD CARD connected on MCI1
2. the optional Dataflash connected on NPCS0 SPI0
3. the 8-bit NAND Flash connected to D0-D7

In this sequence, the first device found with bootable contents is selected as the boot source. The others are disregarded.

On-board jumpers (JP7, JP8) control the selection (CS#) of the on-board bootable memory components (NAND Flash and Serial DataFlash) using a non-inverting 3-state buffer.



Figure 4-10. CS Disable

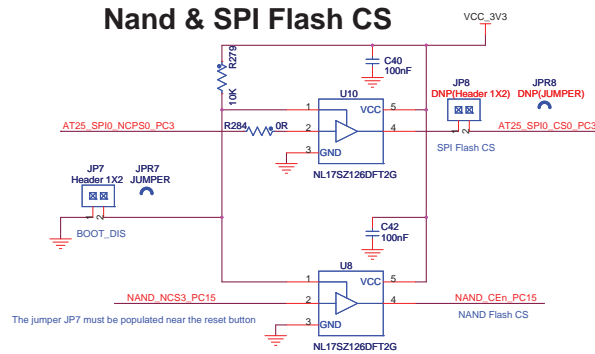

The rule of operation is:

- JP7 = OFF (default) -> enable normal boot from NAND Flash (or serial DataFlash if mounted)
- JP7 = ON -> booting from optional serial DataFlash or NAND Flash is disabled

JP8 (optional) also controls the serial DataFlash if mounted.

Refer to the SAMA5D4 Series datasheet for more information on standard boot strategies and sequencing.

## 4.2.6 Additional Memories

### 4.2.6.1 Serial Data Flash (optional)

The SAMA5D44 provides two high-speed Serial Peripheral Interface (SPI) controllers. One port is used to interface with the optional on-board serial DataFlash.

The four main signals used in the SPI interface are Clock, Data In, Data Out, and Chip Select. The Serial Peripheral Interface (SPI) is a serial interface similar to the I<sup>2</sup>C bus interface but with three main differences:

- It operates at a higher speed
- Transmit and receive data lines are separate
- Device access is chip select-based instead of address-based

Figure 4-11. Optional Serial DataFlash

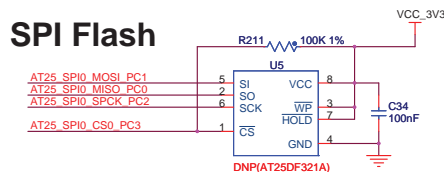

### 4.2.6.2 Serial EEPROM with Unique MAC Address

The SAMA5D4-XULT board embeds one Atmel AT24MAC402/602 EEPROM using a TWI0 interface.

The AT24MAC402/602 provides 2048 bits of Serial Electrically-Erasable Programmable Read-Only Memory (EEPROM) organized as 256 words of eight bits each and is accessed via an I<sup>2</sup>C-compatible (2-wire) serial interface. In addition, the AT24MAC402/602 incorporates an easy and inexpensive method to obtain a globally unique MAC or EUI address (EUI-48 or EUI-64).

The EUI-48/64 addresses can be assigned as the actual physical address of a system hardware device or node, or it can be assigned to a software instance. These addresses are factory-programmed by Atmel and permanently write-protected in an extended memory block located outside of the standard 2-Kbit memory array.

In addition, the AT24MAC402/602 provides the value-added feature of a factory-programmed, guaranteed unique 128-bit serial number located in the extended memory block (same area as the EUI address values).

The EEPROM device is used as a "soft label" to store board information such as chip type, manufacture name and production date, using the last two 16-byte blocks in memory.



The information contained in these blocks should not be modified.

Figure 4-12. EEPROM

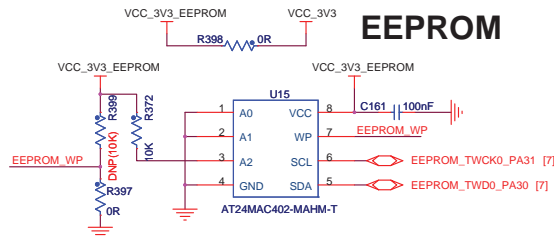

## 4.2.7 High-Speed Multimedia Card Interface (HSMCI)

### 4.2.7.1 Multimedia Card Interface (MCI)

The SAMA5D4-XULT board has two high-speed Multimedia Card interfaces (MCIs) that support the multimedia card (MMC) Specification V4.3, the SD Memory Card Specification V2.0 and the SDIO V1.1 specification:

- **MCI0 interface** based on a 7-pin interface (clock, command, 4-bit data, power lines).
- **MCI1 Interface** based on a 7-pin interface (clock, command, 4-bit data, power lines).

### 4.2.7.2 HSMCI Card Connector

A standard MMC/SD card (push and click type) connector, connected to MCI1, is mounted on the top side of the board. It features a push-lock / push-eject mechanism and a card detection switch.

A micro SD card (push and click type) connector, connected to MCI0, is mountable as an option on the bottom side of the board.

Figure 4-13. HSMCI0 & HSMCI1

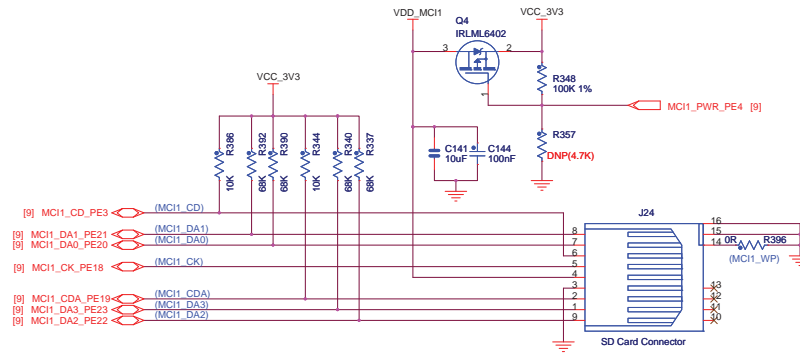

SD/MMCPlus CARD INTERFACE - MCI1

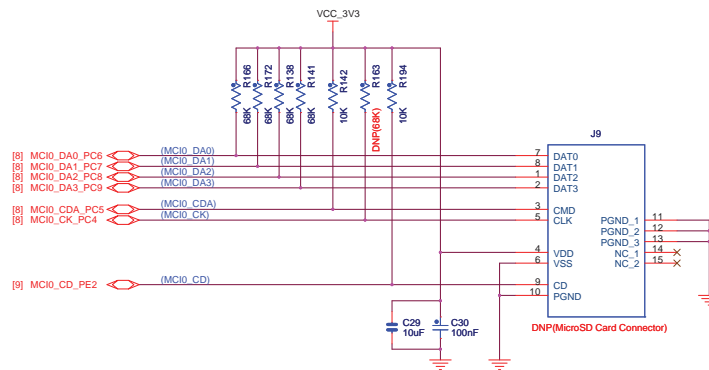

Micro SD CARD INTERFACE - MCI0

## 4.2.8 Communication Interfaces

The SAMA5D4-XULT board is equipped with EMAC and USB Host/Device communication interfaces.

### 4.2.8.1 Ethernet 10/100 (EMAC) Port

The SAMA5D4-XULT board contains a MICREL PHY device (KSZ8081) operating at 10/100 Mb/s. The board supports RMI interface modes. The Ethernet interface consists of two pairs of low-voltage differential pair signals designated from GRX± and GTX± plus control signals for link activity indicators. These signals can be used to connect to a 10/100 Base-T RJ45 connector integrated on SAMA5D4-XULT board.

Additionally, for monitoring and control purposes, LED functionality is carried on the RJ45 connectors to indicate activity, link, and speed status information.

For more information about the Ethernet controller device, refer to the MICREL KSZ8081RN controller manufacturer's datasheet.

**Figure 4-14. Ethernet**

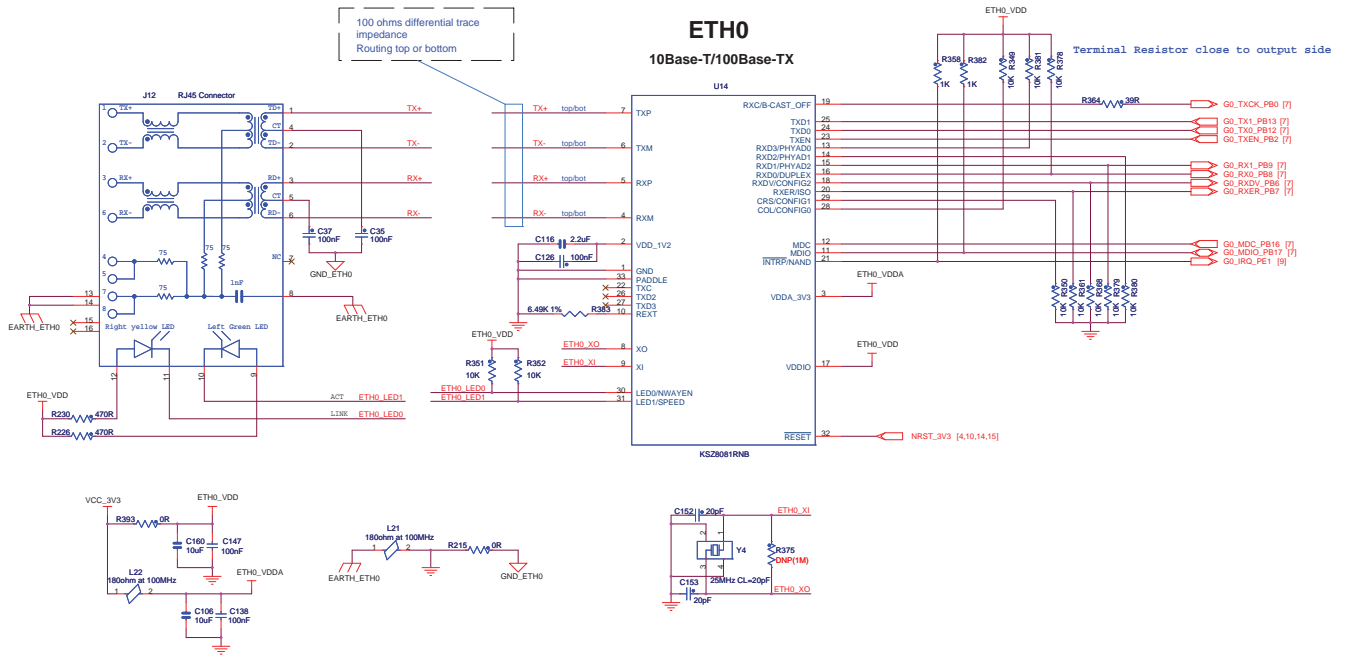

**4.2.8.2 USB Host/Device A, B & C**

The SAMA5D4-XULT board features three USB communication ports:

- USB Host B/C High- and Full-speed Interface
  - Two USB host stacked type A connectors.
- USB Host/Device A Interface
  - One USB device standard micro-AB connector. This port has a VBUS detection function made through the resistor ladder R218 and R214.

**Figure 4-15. USB Host & Device Interface**

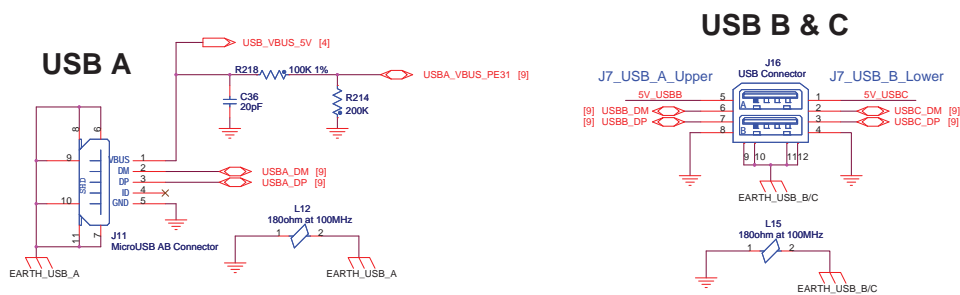

The two USB Host ports are equipped with 500 mA high-side power switch for self-powered and bus-powered applications.

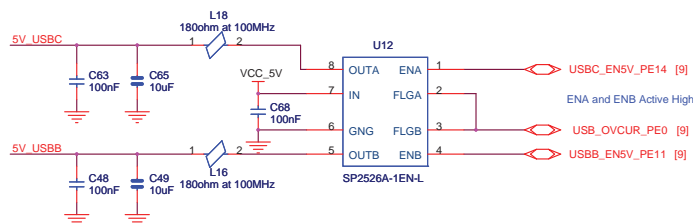

## 4.2.9 LCD TFT Interface

### 4.2.9.1 LCD

The SAMA5D4 provides 24 bits of data and control signals to the LCD interface. Other signals are used to control the LCD and are available on connector J2: TWI, SPI, 2 GPIOs for interrupt, 1-Wire and power supply lines.

### 4.2.9.2 LCD Expansion Header

J2 is a 1.27mm pitch 50-pin header; it gives access to the LCD signals.

Figure 4-16. LCD Expansion Header Interface

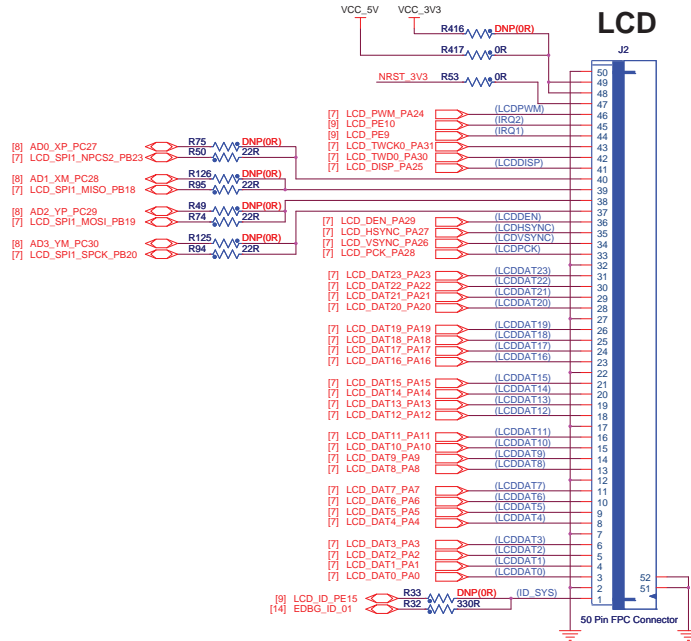

### 4.2.9.3 LCD Power

In order to operate correctly out of the processor with various LCD modules, two voltage lines are available: 3.3V by default and 5 VCC, both selected by 0R resistors R416 and R417.

Figure 4-17. LCD Power

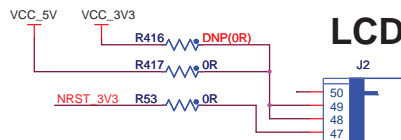

## 4.2.10 HDMI Transmitter Interface

The SAMA5D4-XULT board features the Silicon Image SiI9022ACUN device to convert video signals to the HDMI standard.

It features the following:

- Compliance
  - HDMI 1.2a, Simply HD, DVI 1.0
- Digital Video Output
  - Integrated TMDS core
  - DTV resolution support - 480i/576i/480p/576p/720p/1080i/1080p

- PC resolution support - VGA/XGA/SXGA/WSXGA/UXGA
- Flexible interface to HD MPEG decoders
- Integrated YCbCr -> RGB conversion
- 4:2:2 -> 4:4:4 up-converter
- Digital Audio Output
  - DVD-Audio support through 4 x I2S inputs
  - Supports 2-ch 192kHz or 8-ch 96kHz
  - Supports IEC60958 2-ch PCM or IEC61937 compressed audio (Dolby Digital, DTS, etc.)
  - Industry-standard S/PDIF input, Integrated MCLK generator
- Power Management
  - 1.2V and 1.8V cores provide low-power operation
  - Flexible power-down modes

Figure 4-18. HDMI Interface

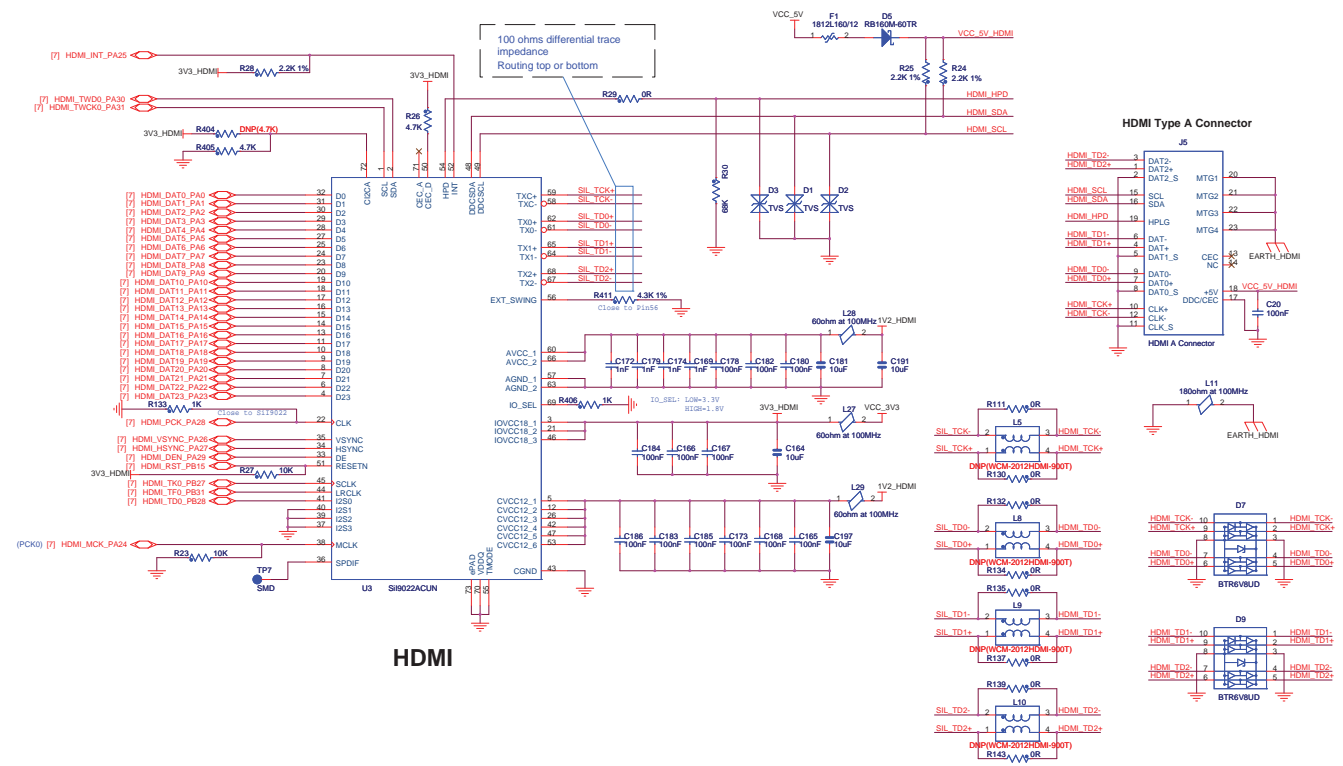

#### 4.2.11 Indicators

There are two LEDs on the SAMA5D4-XULT board that can be controlled by the user:

- The red LED provides an indication that power is supplied to the board and is controlled via software.
- The blue LED is controlled via GPIO pins.

Figure 4-19. LED Indicators

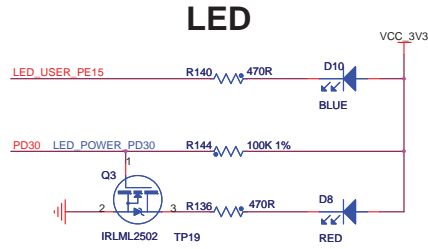

#### 4.2.12 Push Button Switches

The SAMA5D4-XULT features three push buttons:

- One board Reset button (BP3). When pressed and released, it causes a power-on reset of the board.
- One Wakeup push button to exit the processor from low-power mode (BP2).
- One User momentary push button (BP1).

Figure 4-20. Push Buttons

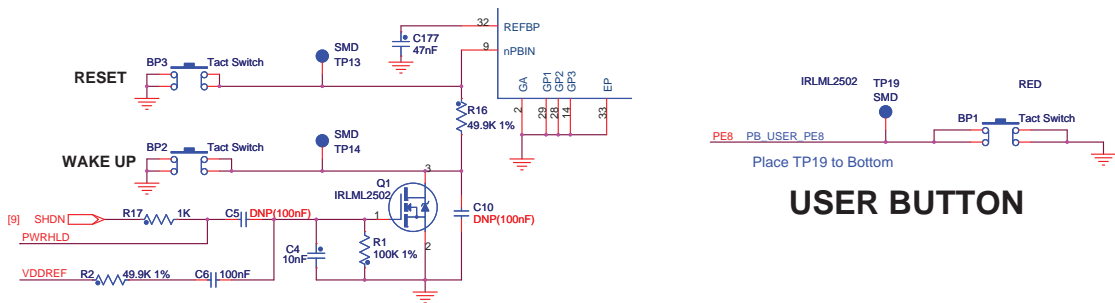

#### 4.2.13 Debug Interfaces

The SAMA5D4-XULT board includes a JTAG, a Debug serial COM port and an EDBG interface port, to provide debug level access to the SAMA5D4.

##### 4.2.13.1 Debug JTAG

A 2x10-pin JTAG header is provided on the SAMA5D4-XULT board to facilitate the software development and debugging by using various JTAG emulators. The interface signals have a voltage level of 3.3V.

Figure 4-21. JTAG Interface

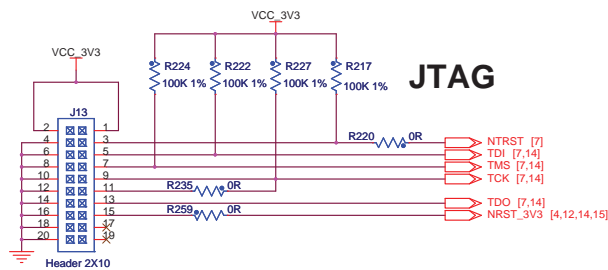

##### 4.2.13.2 DBGU

The SAMA5D4-XULT board has a dedicated serial port for debugging, which is accessible through the 6-pin male header J1. Various interfaces can be used as USB/Serial DBGU port bridge, such as FTDI TTL-232R USB to TTL serial cable or basic breakout board for the RS232/USB converter.

**Figure 4-22. DBGU Interface**

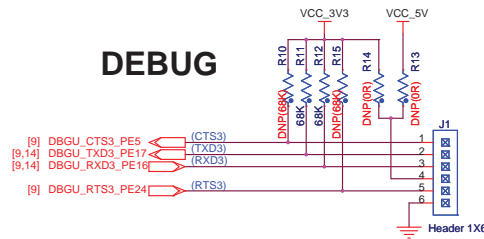

R13 and R14 are optional (not implemented) resistors that can be used for power selection. Power can be delivered either by the SAMA5D4-XULT board or by the debug interface tool. To avoid malfunction between the debug interface (e.g. FTDI) and the on-board power system, ensure that the voltage level selected corresponds to application requirements.

#### 4.2.14 Embedded Debugger (EDBG) Interface

The Atmel Embedded Debugger (EDBG) <sup>(1)</sup> is an intuitive plug-and-play solution which adds full programming and debugging support to embedded hardware kits containing Atmel microcontrollers. It enables seamless integration between the target hardware and the Atmel Studio front end.

In addition to the Virtual COM port which provides a UART bridge to the target device, the EDBG provides a Data Gateway Interface, through which the target device and host PC can communicate, facilitating high-level application debugging, monitoring, graphing and logging of system information in real-time.

The EDBG is based on the Atmel UC3A4 high-performance low-power 32-bit AVR microcontroller running at up to 60 MHz. The device includes an on-chip USB 2.0 high-speed hardware module with dedicated DMA channels, making it ideal for data communications.

By default, the EDBG is in Reset state and not usable. To use the EDBG interface, remove the jumper JP1. To avoid any conflict with the debug signals, do not use the JTAG and EDBG at the same time.

##### 1. Device and Ordering Information

The EDBG is a factory-programmed AT32UC3A4256J-C1UR standard microcontroller with ordering code AT32UC3A4256HHB-C1UR. For further information please contact [edbg@atmel.com](mailto:edbg@atmel.com).



Figure 4-23. EDBG Interface

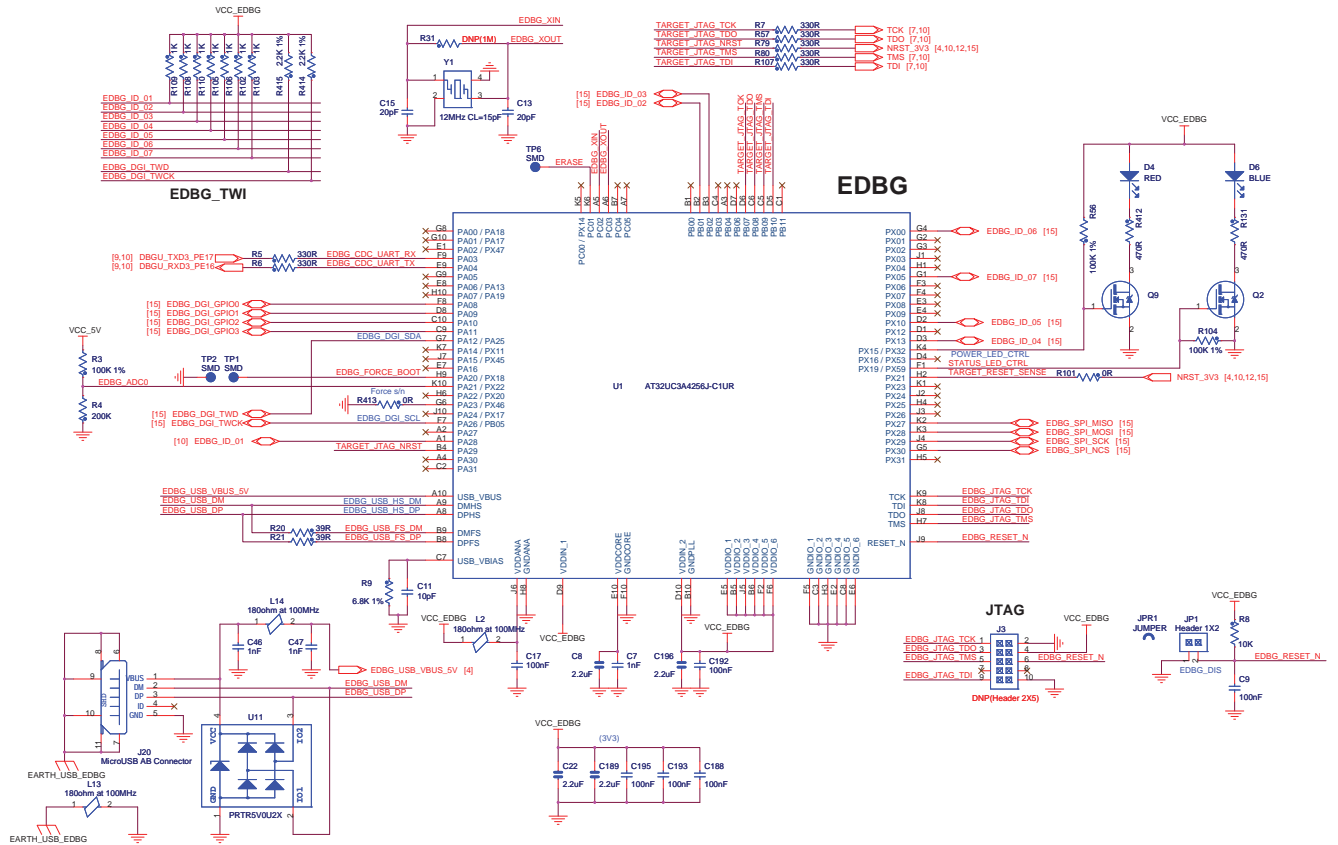

## 4.2.15 Expansion Ports

### 4.2.15.1 Arduino

Five 8-pin, one 6-pin, one 10-pin and one 36-pin headers (J6, J7, J8, J14, J15, J17, J18, J19) are provided on the SAMA5D4-XULT board to enable the PIO connection of various expansion cards. These headers' physical and electrical implementation match the Arduino R3 extension ("shields") scheme.

Due to multiplexing, different signals can be provided on each pin.

Figure 4-24. Expansion Boards Connectors

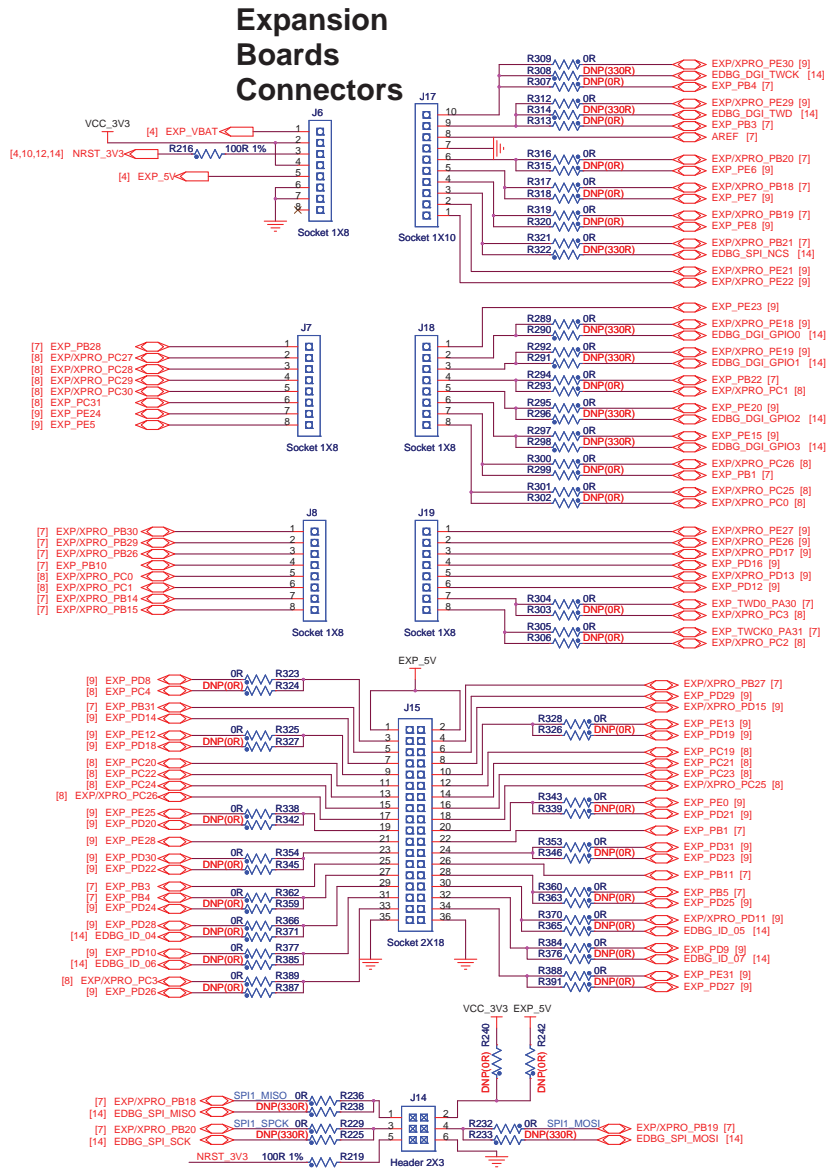

## 4.2.15.2 Functions Available Through the Arduino Headers

The multiplexing of the SAMA5D44 I/Os (standard parallel I/O and up to 3 peripheral functions per pin) makes it possible to route alternate signals via Arduino extension headers. To enable these signals, SAMA5D44 PIO multiplexing must be properly configured. For more details, refer to [Section 4.3.15](#) of this document and the section PIO Controller (PIO) in the SAMA5D4 Series datasheet.

In addition, on-board resistors may be unsoldered and moved to an alternate location to enable a different connection.

[Table 4-5](#) to [Table 4-11](#), together with the connector schematics, provide the alternate signals available for use with Arduino connectors.



### How to read the tables

For the example [Table 4-4](#) and [Figure 4-25](#) below, the information provided on alternate signals is read as follows:

Pin 3 of Jxx is normally connected to SAMA5D44 PD8 which has PCK0 as an alternate function.

By unsoldering R323 and soldering it on R324 footprint, pin 3 of J15 will be connected to SAMA5D44 PC4 which has SPI0\_NPCS1, MCIO\_CK and PCK1 as alternate functions.

**Figure 4-25. Jxx Connector**

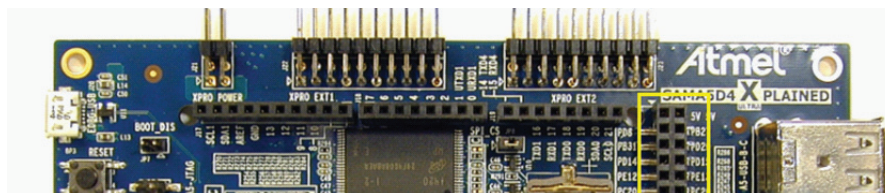

**Table 4-4. Jxx Connector Signals**

Pin Number	SAMA5D44 PIO Muxing Alternates				On-board Alternate			
	PD8	PCK0	–	–	PC4	SPI0_NPCS1	MCIO_CK	PCK1
3	PD8	PCK0	–	–	PC4	SPI0_NPCS1	MCIO_CK	PCK1

Figure 4-26. J6 Connector

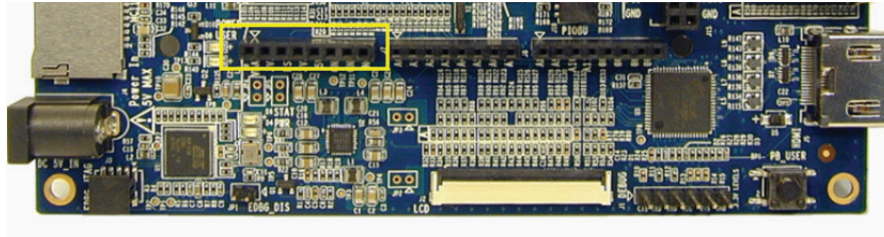
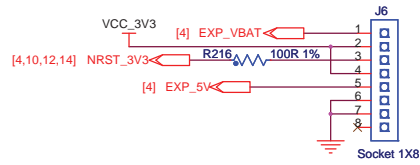

Table 4-5. J6 Connector Signals

Pin Number	Signal				On-board Alternate			
1	EXP_VBAT	-	-	-	-	-	-	-
2	VCC_3V3	-	-	-	-	-	-	-
3	NRST_3V3	-	-	-	-	-	-	-
4	VCC_3V3	-	-	-	-	-	-	-
5	EXP_5V	-	-	-	-	-	-	-
6	GND	-	-	-	-	-	-	-
7	GND	-	-	-	-	-	-	-
8	NC	-	-	-	-	-	-	-

Figure 4-27. J7 Connector

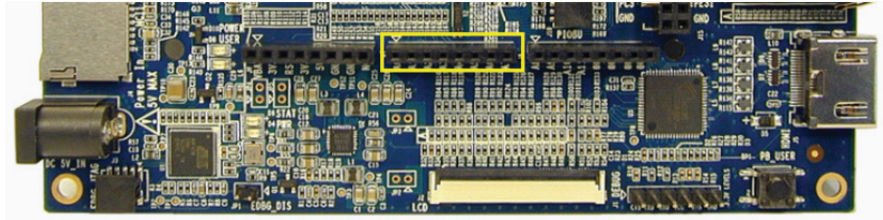
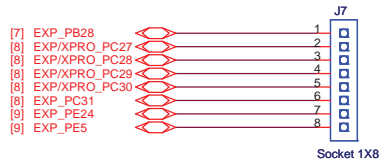
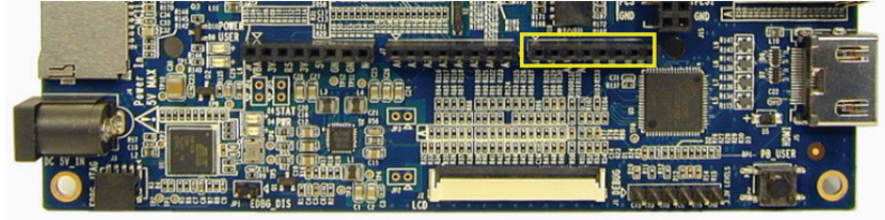
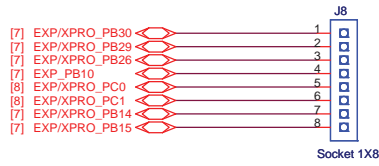

Table 4-6. J7 Connector Signals

Pin Number	SAMA5D44 PIO Muxing Alternates				On-board Alternate			
1	PB28	SPI2_NPCS3	TD0	PWMH1	–	–	–	–
2	PC27	AD0	SPI0_NPCS1	PWML0	–	–	–	–
3	PC28	AD1	SPI0_NPCS2	PWML1	–	–	–	–
4	PC29	AD2	SPI0_NPCS3	PWMF10	–	–	–	–
5	PC30	AD3	–	PWMH0	–	–	–	–
6	PC31	AD4	–	PWMH1	–	–	–	–
7	PE24	NCS0	RTS3	–	–	–	–	–
8	PE5	A5	CTS3	–	–	–	–	–

**Figure 4-28. J8 Connector**



**Table 4-7. J8 Connector Signals**

Pin Number	SAMA5D4 PIO Muxing Alternates				On-board Alternate
1	PB30	TWCK2	RF0	–	–
2	PB29	TWD2	RD0	PWML1	–
3	PB26	PCK0	RK0	PWMH0	–
4	PB10	G0_RX2	PCK2	PWML1	–
5	PC0	SPI0_MISO	PWMH2	ISI_D8	No DAC available
6	PC1	SPI0_MOSI	PWML2	ISI_D9	No DAC available
7	PB14	G0_TX2	SPI2_NPCS1	PWMH0	No CAN available
8	PB15	G0_TX3	SPI2_NPCS2	PWML0	No CAN available

Figure 4-29. J14 Connector

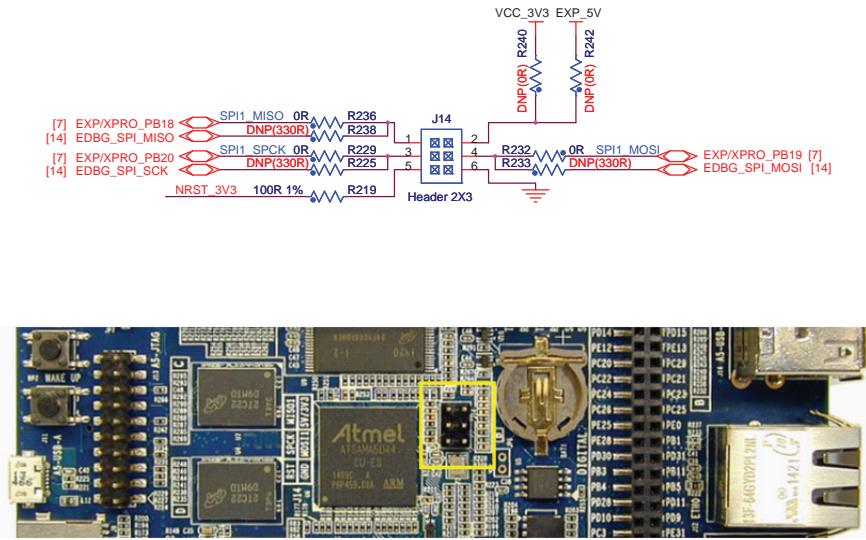
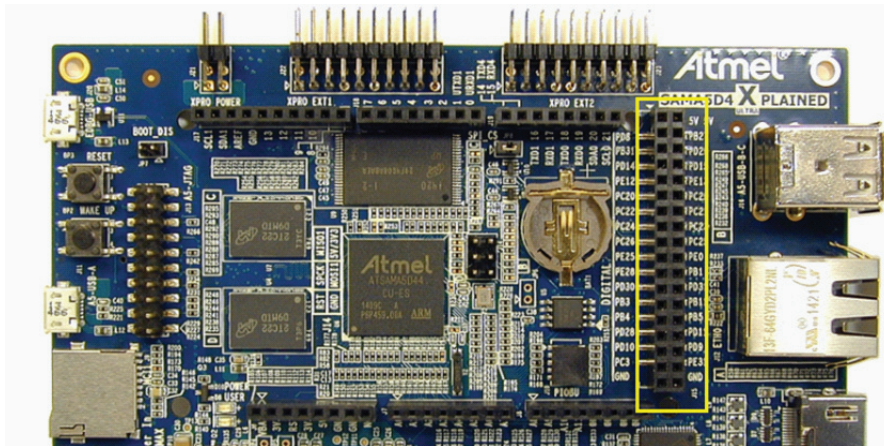
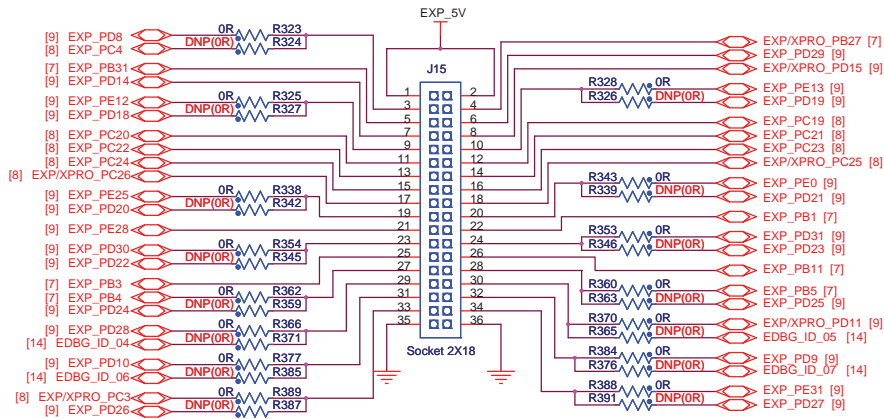

Table 4-8. J14 Connector Signals

Pin Number	SAMA5D4 PIO Muxing Alternates				On-board Alternate				EDBG Alternate
	Pin	Function	Alternate	Alternate	Alternate	Alternate	Alternate	Alternate	
1	PB18	SPI1_MISO	D8	–	–	–	–	–	DGI_SPI
2	5V	–	–	–	–	–	–	–	–
3	PB20	SPI1_SPCK	D10	–	–	–	–	–	DGI_SPI
4	PB19	SPI1_MOSI	D9	–	–	–	–	–	DGI_SPI
5	nRST	–	–	–	–	–	–	–	–
6	GND	–	–	–	–	–	–	–	–



**Figure 4-30. J15 Connector**



**Table 4-9. J15 Connector Signals**

Pin Number	SAMA5D44 PIO Muxing Alternates				On-board Alternate			
	5V	–	–	–	5V	–	–	–
1	5V	–	–	–	5V	–	–	–
2	5V	–	–	–	5V	–	–	–
3	PD8	PCK0	–	–	PC4	SPI0_NPCS1	MCI0_CK	PCK1
4	PB27	SPI1_NPCS3	TK0	PWML0	–	–	–	–
5	PB31	–	TF0	–	–	–	–	–
6	PD29	SCK1	DIS	–	–	–	–	–
7	PD14	CTS1	CDET B	–	–	–	–	–
8	PD15	RTS1	SPI2_SPCK	–	–	–	–	–
9	PE12	A12	TIOA1	PWMLH2	PD18	–	SENSE0	–
10	PE13	A13	TIOB1	PWML2	PD19	–	SENSE1	–
11	PC20	ISI_D1	TF1	–	–	–	–	–
12	PC19	ISI_D0	TK1	–	–	–	–	–



**Table 4-9. J15 Connector Signals (Continued)**

Pin Number	SAMA5D44 PIO Muxing Alternates				On-board Alternate			
13	PC22	ISI_D3	RF1	–	–	–	–	–
14	PC21	ISI_D2	TD1	–	–	–	–	–
15	PC24	ISI_D5	RK1	PCK1	–	–	–	–
16	PC23	ISI_D4	RD1	–	–	–	–	–
17	PC26	ISI_D7	TWCK3	UTXD1	–	–	–	–
18	PC25	ISI_D6	TWD3	URXD1	–	–	–	–
19	PE25	NCS1	SCK4	IRQ	PD20	–	SENSE2	–
20	PE0	A0/NBS0	MCI0_CDB	CTS4	PD21	–	SENSE3	–
21	PE28	NWAIT	RTS4	A19	–	–	–	–
22	PB1	G0_RXCK	SCK2	ISI_PCK	–	–	–	–
23	PD30	–	–	–	PD22	–	SENSE4	–
24	PD31	SPI0_NPCS2	PCK1	–	PD23	–	SENSE5	–
25	PB3	G0_TXER	CTS2	ISI_VSYNC	–	–	–	–
26	PB11	G0_RX3	RTS2	PWMH1	–	–	–	–
27	PB4	G0_CRCS	RXD2	ISI_HSYNC	PD24	–	SENSE6	–
28	PB5	G0_COL	TXD2	PCK2	PD25	–	SENSE7	–
29	PD28	SCK0	–	–	–	–	–	–
30	PD11	RTS0	SPI2_MISO	–	–	–	–	–
31	PD10	CTS0	CDETA	–	–	–	–	–
32	PD9	FIQ	–	–	–	–	–	–
33	PC3	SPI0_NPCS0	PWML3	ISI_D11	PD26	–	SENSE8	–
34	PE31	ADTRG	–	–	PD27	–	SENSE9	–
35	GND	–	–	–	GND	–	–	–
36	GND	–	–	–	GND	–	–	–

Figure 4-31. J17 Connector

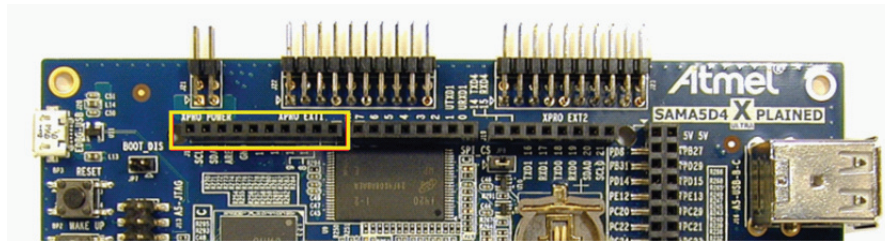
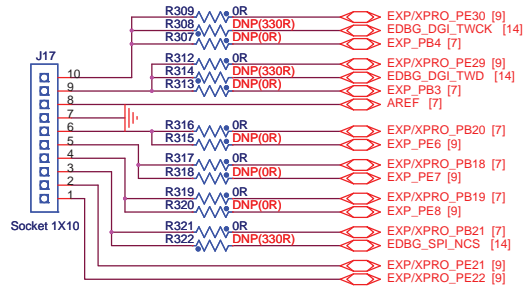

Table 4-10. J17 Connector Signals

Pin Number	SAMA5D4 PIO Muxing Alternates				On-board Alternate				EDBG Alternate
10	PE30	DIBN	UTXD0	TWCK1	PB4	G0_CRS	RXD2	ISI_HSYNC	DGI_TWI
9	PE29	DIBP	URXD0	TWD1	PB3	G0_TXER	CTS2	ISI_VSYNC	DGI_TWI
8	AREF	–	–	–	–	–	–	–	–
7	GND	–	–	–	–	–	–	–	–
6	PB20	SPI1_SPCK	D10	–	PE6	A6	TIOA3	–	–
5	PB18	SPI1_MISO	D8	–	PE7	A7	TIOB3	PWMF1	–
4	PB19	SPI1_MOSI	D9	–	PE8	A8	TCLK3	PWML3	–
3	PB21	SPI1_NPCS0	D11	–	–	–	–	–	DGI_SPI
2	PE21	A23	TIOA4	MCI1_DA1	–	–	–	–	–
1	PE22	A24	TIOB4	MCI1_DA2	–	–	–	–	–

Figure 4-32. J18 Connector

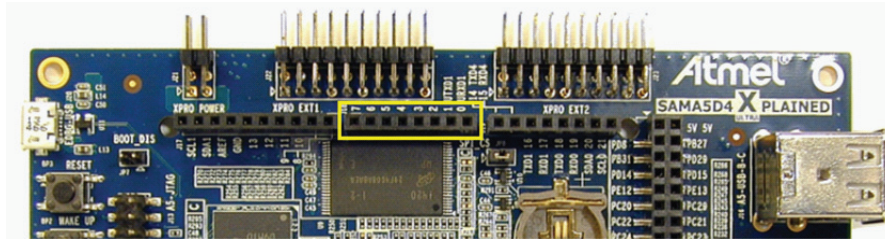
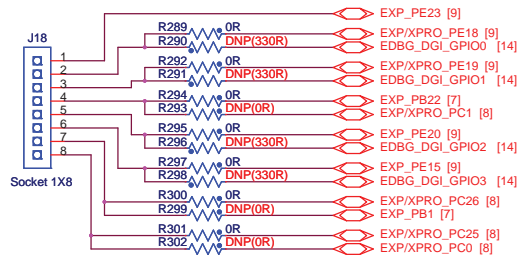

Table 4-11. J18 Connector Signals

Pin Number	SAMA5D4 PIO Muxing Alternates				On-board Alternate				EDBG Alternate
1	PE23	A25	TCLK4	MCI1_DA3	–	–	–	–	–
2	PE18	A18	TIOA5	MCI1_CK	–	–	–	–	DGI_GPIO0
3	PE19	A19	TIOB5	MCI1_CDA	–	–	–	–	DGI_GPIO1
4	PB22	SPI1_NPCS1	D12	–	PC1	SPI0_MOSI	PWML2	ISI_D9	–
5	PE20	A20	TCLK5	MCI1_DA0	–	–	–	–	DGI_GPIO2
6	PE15	A15	SCK3	TIOA0	–	–	–	–	DGI_GPIO3
7	PC26	ISI_D7	TWCK3	UTXD1	PB1	G0_RXCK	SCK2	ISI_PCK	–
8	PC25	ISI_D6	TWD3	URXD1	PC0	SPI0_MISO	PWMH2	ISI_D8	–

Figure 4-33. J19 Connector

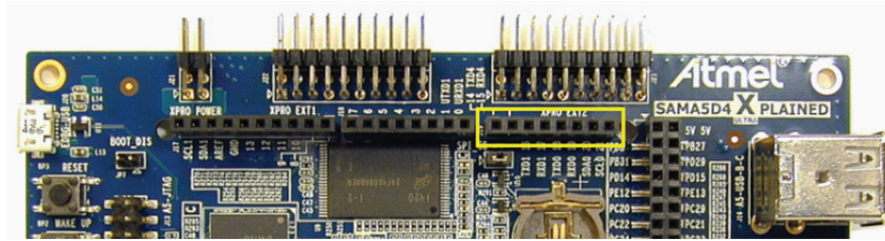
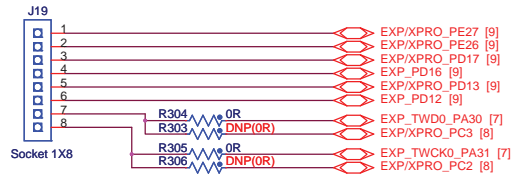

Table 4-12. J19 Connector Signals

Pin Number	SAMA5D44 PIO Muxing Alternates				On-board Alternate			
	PE27	NWR1/NBS1	TXD4	–	–	–	–	–
2	PE26	NCS2	RXD4	A18	–	–	–	–
3	PD17	TXD1	SPI2_NPCS0	–	–	–	–	–
4	PD16	RXD1	DCENB	–	–	–	–	–
5	PD13	TXD0	SPI2_MOSI	–	–	–	–	–
6	PD12	RXD0	DCENA	–	–	–	–	–
7	PA30	TWD0	–	–	PC3	SPI0_NPCS0	PWML3	ISI_D11
8	PA31	TWCK0	–	–	PC2	SPI0_SPCK	PWMH3	ISI_D10

### 4.2.15.3 SAMA5D44 Peripheral Functions Available Through Arduino Headers

Table 4-13 provides details on access to the SAMA5D44 internal peripherals through the Arduino headers.

Note: Only one function at a time can be selected for each pin (refer to Section 4.3.15 in this document and the PIO controller section in SAMA5D4 Series datasheet).

**Table 4-13. SAMA5D44 Peripheral Functions Available through the Arduino Headers**

Connector	SAMA5D4 to Arduino		PCK	ISI	SSC	SPI	TWI	UART/USART	ANALOG	MISC
J14	PB18	–	–	–	–	SPI1_MISO	–	–	–	–
	3v3/5v	3.3V/5V	–	–	–	–	–	–	–	–
	PB20	–	–	–	–	SPI1_SPCK	–	–	–	–
	PB19	–	–	–	–	SPI1_MOSI	–	–	–	–
	nRST	nRST	–	–	–	–	–	–	–	–
	GND	GND	–	–	–	–	–	–	–	–
J7	PB28	–	–	–	TD0	SPI2_NPCS3	–	–	–	PWMH1
	PC27	–	–	–	–	SPI0_NPCS2	–	–	AD0	PWML0
	PC28	–	–	–	–	SPI0_NPCS3	–	–	AD1	PWML1
	PC29	–	–	–	–	–	–	–	AD2	PWMFIO
	PC30	–	–	–	–	–	–	–	AD3	PWMH0
	PC31	–	–	–	–	–	–	–	AD4	PWMH1
	PE24	–	–	–	–	–	RTS3	–	–	–
PE5	–	–	–	–	–	CTS3	–	–	–	
J8	PB30	–	–	–	RF0	–	TWCK2	–	–	–
	PB29	–	–	–	RD0	–	TWD2	–	–	PWML1
	PB26	–	PCK0	–	RK0	–	–	–	–	PWMH0
	PB10	–	PCK2	–	–	–	–	–	–	PWML1
	PC0	–	–	ISI_D8	–	SPI0_MISO	–	–	–	PWMH2
	PC1	–	–	ISI_D9	–	SPI0_MOSI	–	–	–	PWML2
	PB14	–	–	ISI_D10	–	SPI0_SPCK	–	–	–	PWMH0
PB15	–	–	–	–	–	–	–	–	PWML0	
J17	PE30	–	–	ISI_HSYNC	–	–	TWCK1	RXD2	–	–
	PE29	–	–	ISI_VSYNC	–	–	TWD1	CTS2	–	–
	AREF	AREF	–	–	–	–	–	–	–	–
	GND	GND	–	–	–	–	–	–	–	–
	PB20	–	–	–	–	SPI1_SPCK	–	–	–	TIOA3
	PB18	–	–	–	–	SPI1_MISO	–	–	–	TIOB3
	PB19	–	–	–	–	SPI1_MOSI	–	–	–	TCLK3
	PB21	–	–	–	–	SPI1_NPCS0	–	–	–	–
	PE21	–	–	–	–	–	–	–	–	TIOA4
	PE22	–	–	–	–	–	–	–	–	TIOB4

**Table 4-13. SAMA5D4 Peripheral Functions Available through the Arduino Headers (Continued)**

Connector	SAMA5D4 to Arduino		PCK	ISI	SSC	SPI	TWI	UART/ USART	ANALOG	MISC
J18	PE23	-	-	-	-	-	-	-	-	TCLK4
	PE18	-	-	-	-	-	-	-	-	TIOA5
	PE19	-	-	-	-	-	-	-	-	TIOB5
	PB22	-	-	ISI_D9	-	SPI1_NPCS1	-	-	-	-
	PE20	-	-	-	-	SPI2_NPCS1	-	-	-	TCLK5
	PE15	-	-	-	-	SPI2_NPCS2	-	-	-	TIOA0
	PC26	-	-	ISI_D8	-	-	TWCK3	UTXD1	-	PWMH2
	PC25	-	-	ISI_PCK	-	-	TWD3	URXD1	-	-
J19	PE27	-	-	-	-	-	-	TXD4	-	-
	PE26	-	-	-	-	-	-	RXD4	-	-
	PD17	-	-	-	-	SPI2_NPCS0	-	TXD1	-	-
	PD16	-	-	-	-	-	-	RXD1	-	-
	PD13	-	-	-	-	SPI2_MOSI	-	TXD0	-	-
	PD12	-	-	-	-	-	-	RXD0	-	-
	PA30	-	-	ISI_D11	-	SPI0_NPCS0	TWD0	-	-	PWML3
	PA31	-	-	ISI_D10	-	SPI0_SPCK	TWCK0	-	-	PWMH3

**Table 4-13. SAMA5D4 Peripheral Functions Available through the Arduino Headers (Continued)**

Connector	SAMA5D4 to Arduino		PCK	ISI	SSC	SPI	TWI	UART/ USART	ANALOG	MISC
J15	5V	5V	-	-	-	-	-	-	-	-
	5V	5V	-	-	-	-	-	-	-	-
	PD8	-	PCK0/PC K1	-	TK0	-	-	TXD2	-	-
	PB27	-	-	-	TF0	SPI1_NPCS3	-	-	-	PWML0
	PB31	-	-	-	-	-	-	-	-	-
	PD29	-	-	-	-	-	-	SCK1	-	-
	PD14	-	-	-	-	-	TWD0	CTS1	-	-
	PD15	-	-	-	-	SPI2_SPCK	TWCK0	RTS1	-	-
	PE12	-	-	-	-	-	-	-	-	PWMH2
	PE13	-	-	-	-	-	-	-	-	PWML2
	PC20	-	-	ISI_D1	TF1	-	-	-	-	-
	PC19	-	-	ISI_D0	TK1	-	-	-	-	-
	PC22	-	-	ISI_D3	RF1	-	-	-	-	-
	PC21	-	-	ISI_D2	TD1	-	-	-	-	-
	PC24	-	PCK1	ISI_D5	RK1	-	-	-	-	-
	PC23	-	-	ISI_D4	RD1	-	-	-	-	-
	PC26	-	-	ISI_D7	-	-	TWCK3	UTXD1	-	-
	PC25	-	-	ISI_D6	-	-	TWD3	URXD1	-	-
	PE25	-	-	-	-	SPI0_MOSI	-	SCK4	-	-
	PE0	-	-	-	-	SPI0_MISO	-	CTS4	-	-
	PE28	-	-	-	-	SPI0_NPCS0	-	RTS4	-	-
	PB1	-	-	-	-	SPI0_SPCK	-	SCK2	-	-
	PD30	-	-	-	-	-	-	-	-	-
	PD31	-	PCK1	-	-	SPI0_NPCS2	-	-	-	-
	PB3	-	-	-	-	-	-	CTS2	-	-
	PB11	-	-	-	-	-	-	RTS2	-	PWMH1
	PB4	-	-	-	-	-	-	RXD2	-	-
	PB5	-	PCK2	-	-	-	-	TXD2	-	-
	PD28	-	-	-	-	-	-	SCK0	-	-
	PD11	-	-	-	-	-	-	RTS0	-	-
	PD10	-	-	-	-	-	-	CTS0	-	-
	PD9	-	-	-	-	-	-	-	-	-
PC3	-	-	ISI_D11	-	SPI0_NPCS0	-	-	-	PWML3	
PE31	-	-	-	-	-	-	-	-	-	
GND	GND	-	-	-	-	-	-	-	-	
GND	GND	-	-	-	-	-	-	-	-	

#### 4.2.15.4 XPRO

The SAMA5D4-XULT board embeds three connectors to interface Xplained PRO wings.

**Figure 4-34. XPRO Connectors**

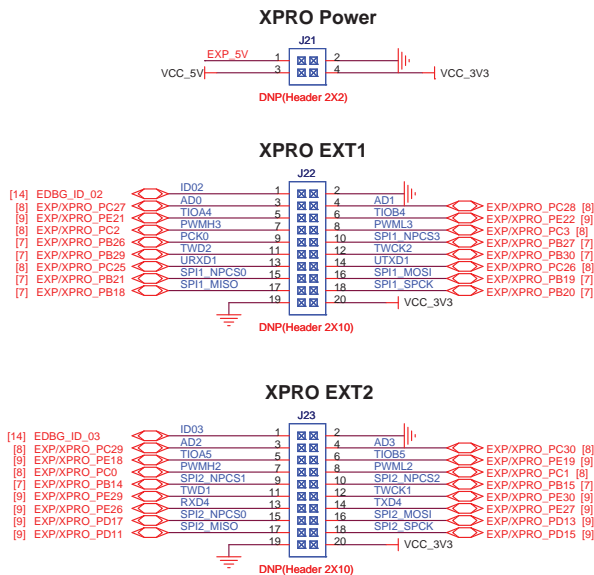

### XPRO Connectors

The standard extension headers include common signals. These are male 20-pin/100-mil/right-angled headers (extension boards feature a female 20-pin straight header).

**Figure 4-35. XPRO Extension Headers**

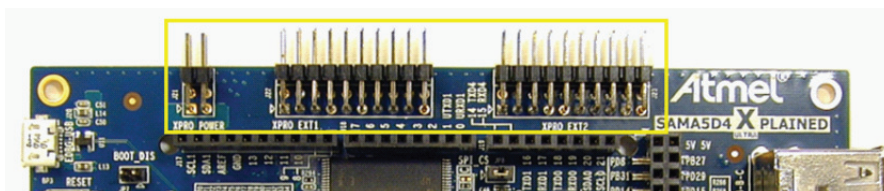



## 4.3 PIO Usage and Interface Connectors

### 4.3.1 Power Supply

Figure 4-36. Power Supply Connector J4

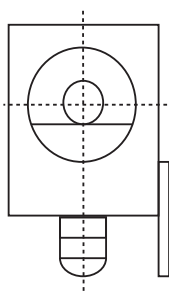

Table 4-14. Power Supply Connector J4 Signal Description

Pin	Mnemonic	Signal Description
1	Center pin	+5V
2	Spring blade	GND
3	Fixing pin	Floating

### 4.3.2 JTAG/ICE Connector

Figure 4-37. JTAG J13

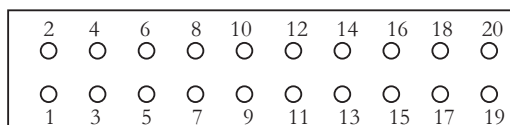

Table 4-15. JTAG/ICE Connector J13 Signal Descriptions

Pin	Mnemonic	Signal Description
1	VTref. 3.3V power	This is the target reference voltage (main 3.3V).
2	Vsupply. 3.3V power	This pin is not connected in SAM-ICE and reserved for compatibility with other equipment. Connected to main 3.3V.
3	nTRST TARGET RESET - Active-low output signal that resets the target	JTAG Reset. Output from SAM-ICE to control the Reset signal on the target system.
4	GND	Common ground.
5	TDI TEST DATA INPUT - Serial data output line, sampled on the rising edge of the TCK signal.	JTAG data input into target CPU.
6	GND	Common ground.
7	TMS TEST MODE SELECT	JTAG mode set input into target CPU.
8	GND	Common ground.

**Table 4-15. JTAG/ICE Connector J13 Signal Descriptions (Continued)**

Pin	Mnemonic	Signal Description
9	TCK TEST CLOCK - Output timing signal, for synchronizing test logic and control register access.	JTAG clock signal into target CPU.
10	GND	Common ground.
11	RTCK - Input Return test clock signal from the target.	Some targets having too slow system clock must synchronize the JTAG inputs to internal clocks. In present case such synchronization is unneeded and TCK merely looped back into RTCK.
12	GND	Common ground.
13	TDO JTAG TEST DATA OUTPUT - Serial data input from the target.	JTAG data output from target CPU.
14	GND	Common ground.
15	nSRST RESET	Active-low reset signal. Target CPU reset signal.
16	GND	Common ground.
17	RFU	This pin is not connected in SAM-ICE.
18	GND	Common ground.
19	RFU	This pin is not connected in SAM-ICE.
20	GND	Common ground.

### 4.3.3 EDBG USB Type Micro-AB

**Figure 4-38. EDBG USB Type Micro-AB Connector J20**

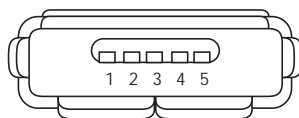

**Table 4-16. EDBG USB Type Micro-AB Connector J20 Signal Descriptions**

Pin	Mnemonic	Signal Description
1	Vbus	5V power
2	DM	Data minus
3	DP	Data plus
4	ID	On-the-go identification
5	GND	Common ground

### 4.3.4 USB Type A Dual Port

Figure 4-39. USB Type A Dual Port J16

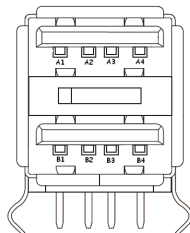

Table 4-17. USB Type A Dual Port J16 Signal Descriptions

Pin	Mnemonic	Signal Description
A1	Vbus - USB_A	5V power
A2	DM - USB_A	Data minus
A3	DP - USB_A	Data plus
A4	GND	Common ground
B1	Vbus - USB_A	5V power
B2	DM - USB_A	Data minus
B3	DP - USB_A	Data plus
B4	GND	Common ground
Mechanical pins	–	Shield

### 4.3.5 USB Micro-AB

Figure 4-40. USB Host/Device Micro-AB Connector J11

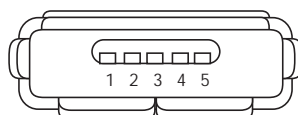

Table 4-18. USB Host/Device Micro-AB Connector J11 Signal Descriptions

Pin	Mnemonic	Signal Description
1	Vbus	5V power
2	DM	Data minus
3	DP	Data plus
4	ID	On-the-go identification
5	GND	Common ground

### 4.3.6 DEBUG Connector

Figure 4-41. DEBUG Connector J1

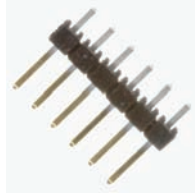

Table 4-19. DEBUG Connector J1 Signal Descriptions

Pin	Mnemonic	PIO	Signal Description
1	CTS3	PE5	Handshake input
2	TXD3 (Transmitted Data)	PE17	RS232 serial data input signal
3	RXD3 (Received Data)	PE16	RS232 serial data output signal
4	Power	–	5V/3.3V (selected by resistors)
5	RTS3	PE24	Handshake output
6	GND	–	Common ground

### 4.3.7 SD/MMC Plus MCI0

Figure 4-42. SD/MMC Socket J24

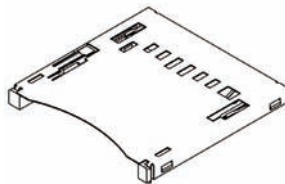

Table 4-20. SD/MMC Socket J24 Signal Descriptions

Pin	Mnemonic	PIO	Signal Description
1	DAT3	PE23	Data Bit
2	CMD	PE19	Command Line
3	VSS	–	Common ground
4	VCC	–	Supply Voltage 3.3V
5	CLK	PE18	Clock / Command Line
6	CD	PE3	CARD DETECT
7	DAT0	PE20	Data Bit
8	DAT1	PE21	Data Bit
9	DAT2	PE22	Data Bit
10	–	n.c.	Data Bit
11	–	n.c.	Data Bit
12	–	n.c.	Data Bit
13	–	n.c.	Data Bit
14	WP	GND	Write Protection (deactivated)
15	–	–	Common ground
16	–	–	Common ground

### 4.3.8 MicroSD MCI1

Figure 4-43. MicroSD Socket J9

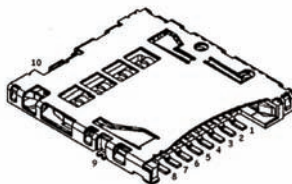

Table 4-21. MicroSD Socket J9 Signal Descriptions

Pin	Mnemonic	PIO	Signal Description
1	DAT2	PC8	Data Bit 2
2	CD/DAT3	PC9	Card Detect / Data Bit 3
3	CMD	PC5	Command Line
4	VCC	–	Supply Voltage 3.3V
5	CLK	PC4	Clock / Command Line
6	VSS	–	Common ground
7	DAT0	PC6	Data Bit 0
8	DAT1	PC7	Data Bit 1
9	CARD DETECT	PE2	CARD DETECT
10	PGND	–	Common ground

### 4.3.9 Ethernet ETH0 RJ45 Socket J12

Figure 4-44. Ethernet RJ45 Socket J12

1 2 3 4 5 6 7 8

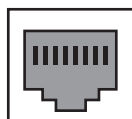

RJ-45

### 4.3.10 LCD Connector J2

Figure 4-45. LCD Connector J2



Table 4-22. LCD Connector J2 Signal Descriptions

Pin	Signal	PIO	Signal	RGB Interface Function	Alternate
1	ID_SYS	PE15 / ID00	ID	Extension module identification	EDBG_ID_01
2	–	GND	GND	GND	–
3	LCDDAT0	PA0	D0	Data line	–
4	LCDDAT1	PA1	D1	Data line	–
5	LCDDAT2	PA2	D2	Data line	–
6	LCDDAT3	PA3	D3	Data line	–
7	–	GND	GND	GND	–
8	LCDDAT4	PA4	D4	Data line	–
9	LCDDAT5	PA5	D5	Data line	–
10	LCDDAT6	PA6	D6	Data line	–
11	LCDDAT7	PA7	D7	Data line	–
12	–	GND	GND	GND	–
13	LCDDAT8	PA8	D8	Data line	–
14	LCDDAT9	PA9	D9	Data line	–
15	LCDDAT10	PA10	D10	Data line	–
16	LCDDAT11	PA11	D11	Data line	–
17	–	GND	GND	GND	–
18	LCDDAT12	PA12	D12	Data line	–
19	LCDDAT13	PA13	D13	Data line	–
20	LCDDAT14	PA14	D14	Data line	–
21	LCDDAT15	PA15	D15	Data line	–
22	–	GND	GND	GND	–
23	LCDDAT16	PC14	D16	Data line	–
24	LCDDAT17	PC13	D17	Data line	–
25	LCDDAT18	PC12	D18	Data line	–
26	LCDDAT19	PC11	D19	Data line	–
27	–	GND	GND	GND	–
28	LCDDAT20	PC10	D20	Data line	–
29	LCDDAT21	PC15	D21	Data line	–

**Table 4-22. LCD Connector J2 Signal Descriptions (Continued)**

Pin	Signal	PIO	Signal	RGB Interface Function	Alternate	
30	LCDDAT22	PE27	D22	Data line	–	
31	LCDDAT23	PE28	D23	Data line	–	
32	–	GND	GND	GND	–	
33	LCDPCK	PA28	PCLK	Pixel clock	–	
34	LCDVSYNC	PA26	VSYNC/CS	Vertical sync	–	
35	LCDHSYNC	PA27	HSYNC/WE	Horizontal sync	–	
36	LCDDEN	PA29	DATA_ENABLE/RE	Data enable	–	
37	SPI1_SPCK	PB20	SPI_SCK	–	AD3/YM	PC30
38	SPI1_MOSI	PB19	SPI_MOSI	–	AD2/YP	PC29
39	SPI1_MISO	PB18	SPI_MISO	–	AD1/XM	PC28
40	SPI1_NPCS2	PB23	SPI_CS	–	AD0/XP	PC27
41	LCDDISP	PA25	ENABLE	Display enable signal	–	
42	TWD0	PA30	TWI_SDA	I2C data line (maXTouch)	–	
43	TWCK0	PA31	TWI_SCL	I2C clock line (maXTouch)	–	
44	GPIO	PE9	IRQ1	maXTouch interrupt line	–	
45	GPIO	PE10	IRQ2	Interrupt line for other I2C devices	–	
46	LCDPWM	PA26	PWM	Backlight control	–	
47	RESET	–	RESET	Reset for both display and maXTouch	–	
48	Main_5v/3v3	VCC	VCC	3.3V or 5v supply (0R)	–	
49	Main_5v/3v3	VCC	VCC	3.3V or 5v supply (0R)	–	
50	GND	GND	GND	GND	–	



### 4.3.11 HDMI Connector

Figure 4-46. HDMI Type A Female Connector J5

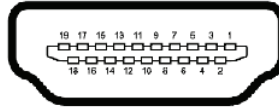

Table 4-23. HDMI Type A Female Connector J5 Signal Descriptions

Signal	Pin Number		Signal
TMDS Data 2+	1	2	TMDS Data 2 Shield
TMDS Data 2-	3	4	TMDS Data 1+
TMDS Data 1 Shield	5	6	TMDS Data 1-
TMDS Data 0+	7	8	TMDS Data 0 Shield
TMDS Data 0-	9	10	TMDS Clock +
TMDS Clock Shield	11	12	TMDS Clock -
CEC (n.c.)	13	14	n.c.
SCL	15	16	SDA
GND	17	18	+5V
Hot Plug Detect	19	20	DDC/CEC (GND)

### 4.3.12 XPRO Power Connector

Figure 4-47. XPRO Power Connector J21

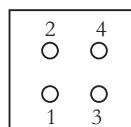

Table 4-24. XPRO Power Connector J21 Signal Descriptions

Signal	Pin Number		Signal
EXP_5V	1	2	GND
VCC_5V	3	4	VCC_3v3

### 4.3.13 XPRO Ext1 Connector

Figure 4-48. XPRO Ext1 Connector J22

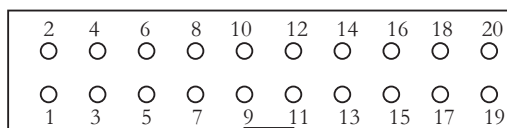

Table 4-25. XPRO Ext1 Connector J22 Signal Descriptions

SAMA5D44 Function	SAMA5D44 Pin	XPRO Signal	Pin Number		XPRO Signal	SAMA5D44 Pin	SAMA5D44 Function
ID02 <sup>(1)</sup>	EDBG <sup>(1)</sup>	ID	1	2	GND	–	–
AD0	PC27	ADC(+)	3	4	ADC(-)	PC28	AD1
TIOA4	PE21	GPIO	5	6	GPIO	PE22	TIOBA4
PWMH3	PC2	PWM(+)	7	8	PWM(-)	PC3	PWML3
PCK0	PB26	IRQ/GPIO	9	10	SPI_SS_B/GPIO	PB27	SPI1_NPCS3
TWD2	PB29	TWI_SDA	11	12	TWI_SCL	PB30	TWCK2
URXD1	PC25	UART_RX	13	14	UART_TX	PC26	UTXD1
SPI1_NPCS0	PB21	SPI_SS_A	15	16	SPI_MOSI	PB19	SPI1_MOSI
SPI1_MISO	PB18	SPI_MISO	17	18	SPI_SCK	PB20	SPI1_SPCK
–	–	GND	19	20	VCC 3v3	–	–

Note: 1. Used by the EDBG interface.

### 4.3.14 XPRO Ext2 Connector

Figure 4-49. XPRO Ext2 Connector J23

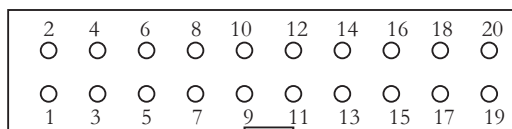

Table 4-26. XPRO Ext2 Connector J23 Signal Descriptions

SAMA5D44 Function	SAMA5D44 Pin	XPRO Signal	Pin Number		XPRO Signal	SAMA5D44 Pin	SAMA5D44 Function
ID03 <sup>(1)</sup>	EDBG <sup>(1)</sup>	ID	1	2	GND	–	–
AD2	PC29	ADC(+)	3	4	ADC(-)	PC30	AD3
TIOA5	PE18	GPIO	5	6	GPIO	PE19	TIOB5
PWMH2	PC0	PWM(+)	7	8	PWM(-)	PC1	PWML2
SPI2_NPCS1	PB14	IRQ/GPIO	9	10	SPI_SS_B/GPIO	PB15	SPI2_NPCS2
TWD1	PE29	TWI_SDA	11	12	TWI_SCL	PE30	TWCK1
RXD4	PE26	UART_RX	13	14	UART_TX	PE27	TXD4
SPI2_NPCS0	PD17	SPI_SS_A	15	16	SPI_MOSI	PD13	SPI2_MOSI
SPI2_MISO	PD11	SPI_MISO	17	18	SPI_SCK	PD15	SPI2_SPCK
–	–	GND	19	20	VCC 3v3	–	–

Note: 1. Used by the EDBG interface.

### 4.3.15 PIO Usage

Table 4-27 provides the use of different PIO lines on the SAMA5D4-XULT, sorted by PIO lines.

Most of the signals can also be configured as either inputs or outputs from/to the processor.

**Table 4-27. PIO A Pin Assignment and Signal Description**

Power Rail	I/O Type	Primary Signal	PeriphA Signal	PeriphB Signal	PeriphC Signal
VDDIOP	GPIO	PA0	LCDDAT0	–	TMS
VDDIOP	GPIO	PA1	LCDDAT1	–	–
VDDIOP	GPIO_CLK	PA2	LCDDAT2	G1_TXCK	–
VDDIOP	GPIO_CLK	PA3	LCDDAT3	G1_RXCK	–
VDDIOP	GPIO	PA4	LCDDAT4	G1_TXEN	–
VDDIOP	GPIO	PA5	LCDDAT5	G1_TXER	–
VDDIOP	GPIO	PA6	LCDDAT6	G1_CRS	–
VDDIOP	GPIO	PA7	LCDDAT7	–	–
VDDIOP	GPIO	PA8	LCDDAT8	–	TCK
VDDIOP	GPIO	PA9	LCDDAT9	–	–
VDDIOP	GPIO	PA10	LCDDAT10	G1_RXDV	–
VDDIOP	GPIO	PA11	LCDDAT11	G1_RXER	–
VDDIOP	GPIO	PA12	LCDDAT12	G1_RX0	–
VDDIOP	GPIO	PA13	LCDDAT13	G1_RX1	–
VDDIOP	GPIO	PA14	LCDDAT14	G1_TX0	–
VDDIOP	GPIO	PA15	LCDDAT15	G1_TX1	–
VDDIOP	GPIO	PA16	LCDDAT16	–	NTRST
VDDIOP	GPIO	PA17	LCDDAT17	–	–
VDDIOP	GPIO	PA18	LCDDAT18	G1_RX2	–
VDDIOP	GPIO	PA19	LCDDAT19	G1_RX3	–
VDDIOP	GPIO	PA20	LCDDAT20	G1_TX2	–
VDDIOP	GPIO	PA21	LCDDAT21	G1_TX3	–
VDDIOP	GPIO	PA22	LCDDAT22	G1_MDC	–
VDDIOP	GPIO	PA23	LCDDAT23	G1_MDIO	–
VDDIOP	GPIO_CLK	PA24	LCDPWM	PCK0	–
VDDIOP	GPIO	PA25	LCDDISP	TD0	–
VDDIOP	GPIO	PA26	LCDVSYNC	PWMH0	SPI1_NPCS1
VDDIOP	GPIO	PA27	LCDHSYNC	PWML0	SPI1_NPCS2
VDDIOP	GPIO_CLK2	PA28	LCDPCK	PWMH1	SPI1_NPCS3
VDDIOP	GPIO	PA29	LCDDEN	PWML1	–
VDDIOP	GPIO	PA30	TWD0	–	–
VDDIOP	GPIO	PA31	TWCK0	–	–

**Table 4-28. PIO B Pin Assignment and Signal Description**

		<b>Primary</b>	<b>PeriphA</b>	<b>PeriphB</b>	<b>PeriphC</b>
<b>Power Rail</b>	<b>I/O Type</b>	<b>Signal</b>	<b>Signal</b>	<b>Signal</b>	<b>Signal</b>
VDDIOP	GPIO_CLK	PB0	G0_TXCK	–	–
VDDIOP	GPIO_CLK	PB1	G0_RXCK	SCK2	ISI_PCK
VDDIOP	GPIO	PB2	G0_TXEN	–	–
VDDIOP	GPIO	PB3	G0_TXER	CTS2	ISI_VSYNC
VDDIOP	GPIO	PB4	G0_CRCS	RXD2	ISI_HSYNC
VDDIOP	GPIO	PB5	G0_COL	TXD2	PCK2
VDDIOP	GPIO	PB6	G0_RXDV	–	–
VDDIOP	GPIO	PB7	G0_RXER	–	–
VDDIOP	GPIO	PB8	G0_RX0	–	–
VDDIOP	GPIO	PB9	G0_RX1	–	–
VDDIOP	GPIO_CLK	PB10	G0_RX2	PCK2	PWML1
VDDIOP	GPIO	PB11	G0_RX3	RTS2	PWMH1
VDDIOP	GPIO	PB12	G0_TX0	–	–
VDDIOP	GPIO	PB13	G0_TX1	–	–
VDDIOP	GPIO	PB14	G0_TX2	SPI2_NPCS1	PWMH0
VDDIOP	GPIO	PB15	G0_TX3	SPI2_NPCS2	PWML0
VDDIOP	GPIO	PB16	G0_MDC	–	–
VDDIOP	GPIO	PB17	G0_MDIO	–	–
VDDIOP	GPIO	PB18	SPI1_MISO	D8	–
VDDIOP	GPIO	PB19	SPI1_MOSI	D9	–
VDDIOP	GPIO_CLK	PB20	SPI1_SPCK	D10	–
VDDIOP	GPIO	PB21	SPI1_NPCS0	D11	–
VDDIOP	GPIO	PB22	SPI1_NPCS1	D12	–
VDDIOP	GPIO	PB23	SPI1_NPCS2	D13	–
VDDIOP	GPIO	PB24	DRXD	D14	TDI
VDDIOP	GPIO	PB25	DTXD	D15	TDO
VDDIOP	GPIO_CLK	PB26	PCK0	RK0	PWMH0
VDDIOP	GPIO	PB27	SPI1_NPCS3	TK0	PWML0
VDDIOP	GPIO	PB28	SPI2_NPCS3	TD0	PWMH1
VDDIOP	GPIO	PB29	TWD2	RD0	PWML1
VDDIOP	GPIO	PB30	TWCK2	RF0	–
VDDIOP	GPIO	PB31	–	TF0	–

**Table 4-29. PIO C Pin Assignment and Signal Description**

		<b>Primary</b>	<b>PeriphA</b>	<b>PeriphB</b>	<b>PeriphC</b>
<b>Power Rail</b>	<b>I/O Type</b>	<b>Signal</b>	<b>Signal</b>	<b>Signal</b>	<b>Signal</b>
VDDIOM	GPIO	PC0	SPI0_MISO	PWMH2	ISI_D8
VDDIOM	GPIO	PC1	SPI0_MOSI	PWML2	ISI_D9
VDDIOM	GPIO_CLK	PC2	SPI0_SPCK	PWMH3	ISI_D10
VDDIOM	GPIO	PC3	SPI0_NPCS0	PWML3	ISI_D11
VDDIOM	MCI_CLK	PC4	SPI0_NPCS1	MCI0_CK	PCK1
VDDIOM	GPIO	PC5	D0	MCI0_CDA	–
VDDIOM	GPIO	PC6	D1	MCI0_DA0	–
VDDIOM	GPIO	PC7	D2	MCI0_DA1	–
VDDIOM	GPIO	PC8	D3	MCI0_DA2	–
VDDIOM	GPIO	PC9	D4	MCI0_DA3	–
VDDIOM	GPIO	PC10	D5	MCI0_DA4	–
VDDIOM	GPIO	PC11	D6	MCI0_DA5	–
VDDIOM	GPIO	PC12	D7	MCI0_DA6	–
VDDIOM	GPIO	PC13	NRD/NANDOE	MCI0_DA7	–
VDDIOM	GPIO	PC14	NWE/NANDWE	–	–
VDDIOM	GPIO	PC15	NCS3	–	–
VDDIOM	GPIO	PC16	NANDRDY	–	–
VDDIOM	GPIO	PC17	A21/NANDALE	–	–
VDDIOM	GPIO	PC18	A22/NANDCLE	–	–
VDDIOM	GPIO	PC19	ISI_D0	TK1	–
VDDIOM	GPIO	PC20	ISI_D1	TF1	–
VDDIOM	GPIO	PC21	ISI_D2	TD1	–
VDDIOM	GPIO	PC22	ISI_D3	RF1	–
VDDIOM	GPIO	PC23	ISI_D4	RD1	–
VDDIOM	GPIO	PC24	ISI_D5	RK1	PCK1
VDDIOM	GPIO	PC25	ISI_D6	TWD3	URXD1
VDDIOM	GPIO	PC26	ISI_D7	TWCK3	UTXD1
VDDANA	GPIO_ANA	PC27	AD0	SPI0_NPCS1	PWML0
VDDANA	GPIO_ANA	PC28	AD1	SPI0_NPCS2	PWML1
VDDANA	GPIO_ANA	PC29	AD2	SPI0_NPCS3	PWMFIO
VDDANA	GPIO_ANA	PC30	AD3	–	PWMH0
VDDANA	GPIO_ANA	PC31	AD4	–	PWMH1

**Table 4-30. PIO D Pin Assignment and Signal Description**

PIOD Mode Secure		Primary	PeriphA	PeriphB	PeriphC
Power Rail	I/O Type	Signal	Signal	Signal	Signal
VDDIOP	GPIO_CLK	PD8	PCK0	–	–
VDDIOP	GPIO	PD9	FIQ	–	–
VDDIOP	GPIO	PD10	CTS0	CDETA	–
VDDIOP	GPIO	PD11	RTS0	SPI2_MISO	–
VDDIOP	GPIO	PD12	RXD0	DCENA	–
VDDIOP	GPIO	PD13	TXD0	SPI2_MOSI	–
VDDIOP	GPIO	PD14	CTS1	CDETB	–
VDDIOP	GPIO	PD15	RTS1	SPI2_SPCK	–
VDDIOP	GPIO	PD16	RXD1	DCENB	–
VDDIOP	GPIO	PD17	TXD1	SPI2_NPCS0	–
VDDANA	GPIO_ANA	PD18	–	SENSE0	–
VDDANA	GPIO_ANA	PD19	–	SENSE1	–
VDDANA	GPIO_ANA	PD20	–	SENSE2	–
VDDANA	GPIO_ANA	PD21	–	SENSE3	–
VDDANA	GPIO_ANA	PD22	–	SENSE4	–
VDDANA	GPIO_ANA	PD23	–	SENSE5	–
VDDANA	GPIO_ANA	PD24	–	SENSE6	–
VDDANA	GPIO_ANA	PD25	–	SENSE7	–
VDDANA	GPIO_ANA	PD26	–	SENSE8	–
VDDANA	GPIO_ANA	PD27	–	SENSE9	–
VDDIOP	GPIO_CLK	PD28	SCK0	–	–
VDDIOP	GPIO_CLK	PD29	SCK1	DIS	–
VDDIOP	GPIO	PD30	–	–	–
VDDIOP	GPIO_CLK	PD31	SPI0_NPCS2	PCK1	–

**Table 4-31. PIO E Pin Assignment and Signal Description**

		<b>Primary</b>	<b>PeriphA</b>	<b>PeriphB</b>	<b>PeriphC</b>
<b>Power Rail</b>	<b>I/O Type</b>	<b>Signal</b>	<b>Signal</b>	<b>Signal</b>	<b>Signal</b>
VDDIOM	MCI_CLK	PE0	A0/NBS0	MCI0_CDB	CTS4
VDDIOM	EBI	PE1	A1	MCI0_DB0	–
VDDIOM	EBI	PE2	A2	MCI0_DB1	–
VDDIOM	EBI	PE3	A3	MCI0_DB2	–
VDDIOM	EBI	PE4	A4	MCI0_DB3	–
VDDIOM	EBI	PE5	A5	CTS3	–
VDDIOM	EBI	PE6	A6	TIOA3	–
VDDIOM	EBI	PE7	A7	TIOB3	PWMF1
VDDIOM	EBI	PE8	A8	TCLK3	PWML3
VDDIOM	EBI	PE9	A9	TIOA2	–
VDDIOM	EBI	PE10	A10	TIOB2	–
VDDIOM	EBI	PE11	A11	TCLK2	–
VDDIOM	EBI	PE12	A12	TIOA1	PWMH2
VDDIOM	EBI	PE13	A13	TIOB1	PWML2
VDDIOM	EBI	PE14	A14	TCLK1	PWMH3
VDDIOM	EBI	PE15	A15	SCK3	TIOA0
VDDIOM	EBI	PE16	A16	RXD3	TIOB0
VDDIOM	EBI	PE17	A17	TXD3	TCLK0
VDDIOM	EBI	PE18	A18	TIOA5	MCI1_CK
VDDIOM	EBI	PE19	A19	TIOB5	MCI1_CDA
VDDIOM	EBI	PE20	A20	TCLK5	MCI1_DA0
VDDIOM	EBI	PE21	A23	TIOA4	MCI1_DA1
VDDIOM	EBI	PE22	A24	TIOB4	MCI1_DA2
VDDIOM	EBI	PE23	A25	TCLK4	MCI1_DA3
VDDIOM	EBI	PE24	NCS0	RTS3	–
VDDIOM	EBI	PE25	NCS1	SCK4	IRQ
VDDIOM	EBI	PE26	NCS2	RXD4	A18
VDDIOM	EBI	PE27	NWR1/NBS1	TXD4	–
VDDIOM	EBI	PE28	NWAIT	RTS4	A19
VDDIOP	DIB	PE29	DIBP	URXD0	TWD1
VDDIOP	DIB	PE30	DIBN	UTXD0	TWCK1
VDDIOP	GPIO	PE31	ADTRG	–	–



## 4.4 SAMA5D4-XULT Board Schematics

This section contains the following schematics:

- Block Diagram
- PIO Muxing Table
- Power Supply
- SAMA5D44 - Power
- SAMA5D44 - DDR2
- SAMA5D44 - PIOA and PIOB
- SAMA5D44 - PIOC and Flash
- SAMA5D44 - SYS, PIOD and PIOE
- JTAG, USB, DEBUG and LCD
- HDMI
- Ethernet\_ETH0\_10/100M
- HSMCI
- EDBG
- Expansion and XPRO Connectors

Figure 4-50. Block diagram

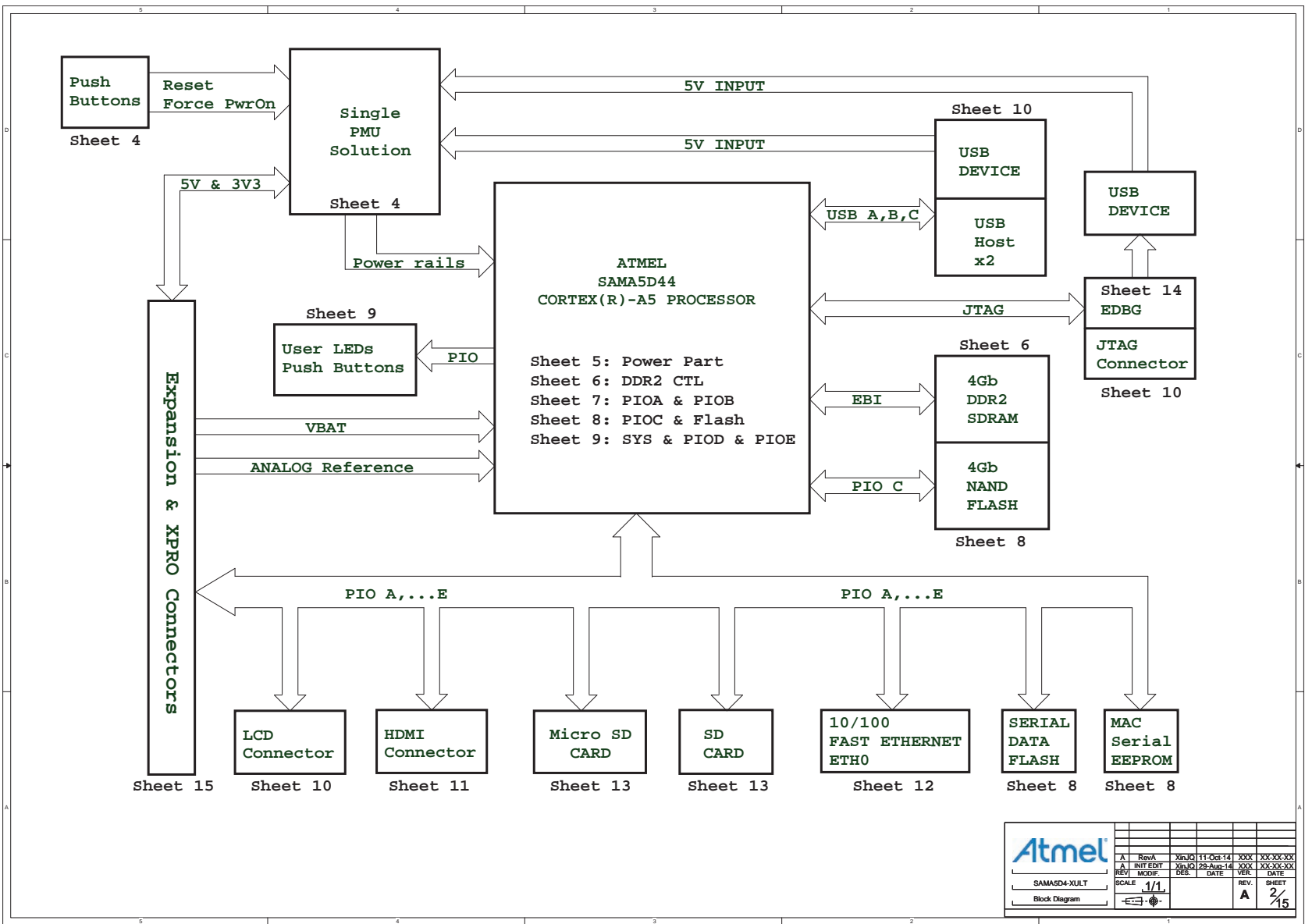

Atmel					
A	RevA	XinJi	11-Oct-14	XXX	XXXXXXXX
A	INIT EDIT	XinJi	28-Aug-14	XXX	XXXXXXXX
REV	MODIF	DES	DATE	YES	DATE
SAM5D4-XULT		SCALE	1/1	REV	SHEET
Block Diagram				A	2/15



Figure 4-52. Power Supply

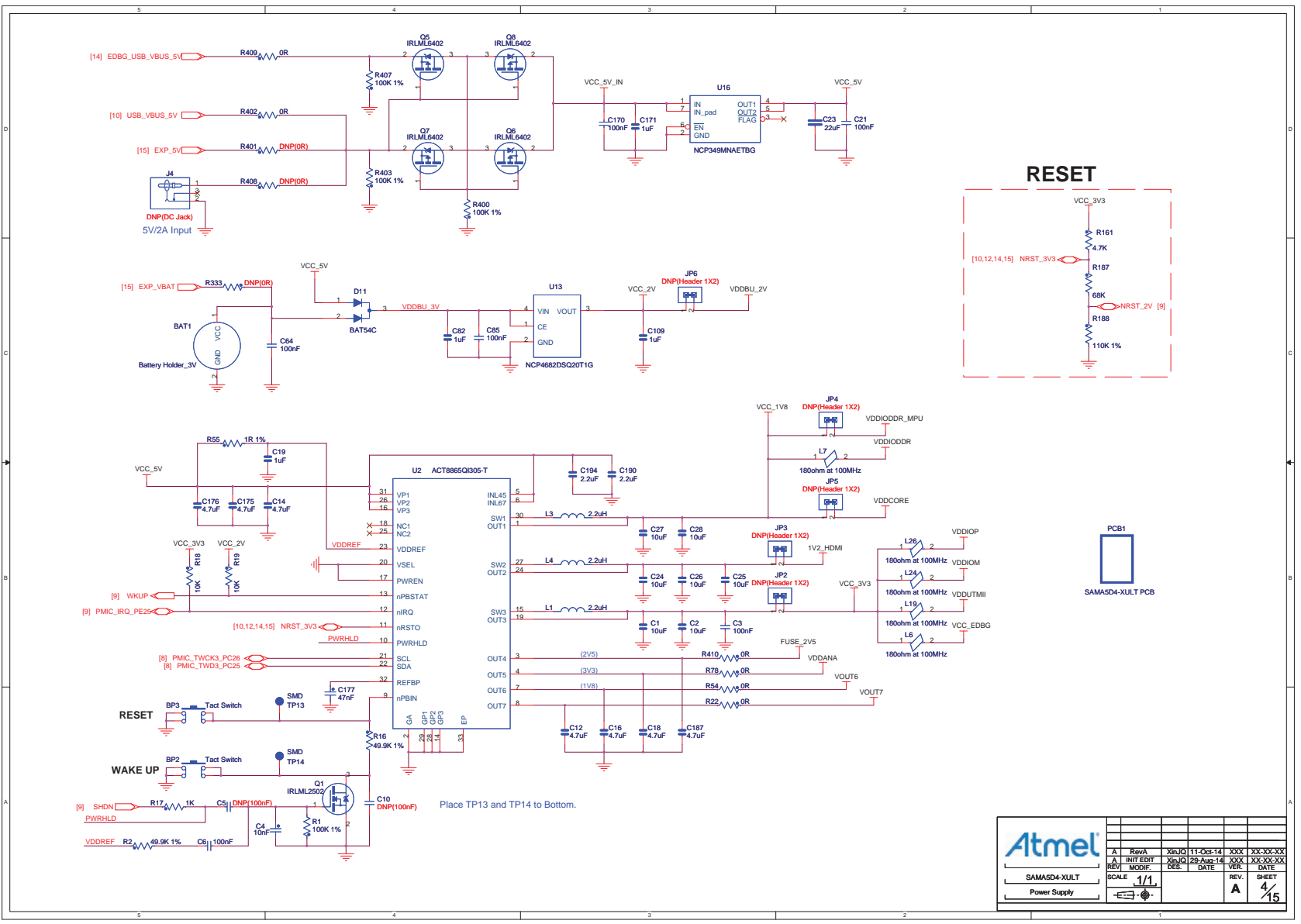

Atmel					
A	RevA	XinQ	11-Oct-14	XXX	XX-XX-XX
A	INIT EDIT	XinQ	28-Aug-14	XXX	XX-XX-XX
REV	MODIF	DES	DATE	VER	DATE
SAMASD4-XULT		SCALE	1/1	REV	A
Power Supply				SHEET	4/15



Figure 4-53. SAM5D44 - Power

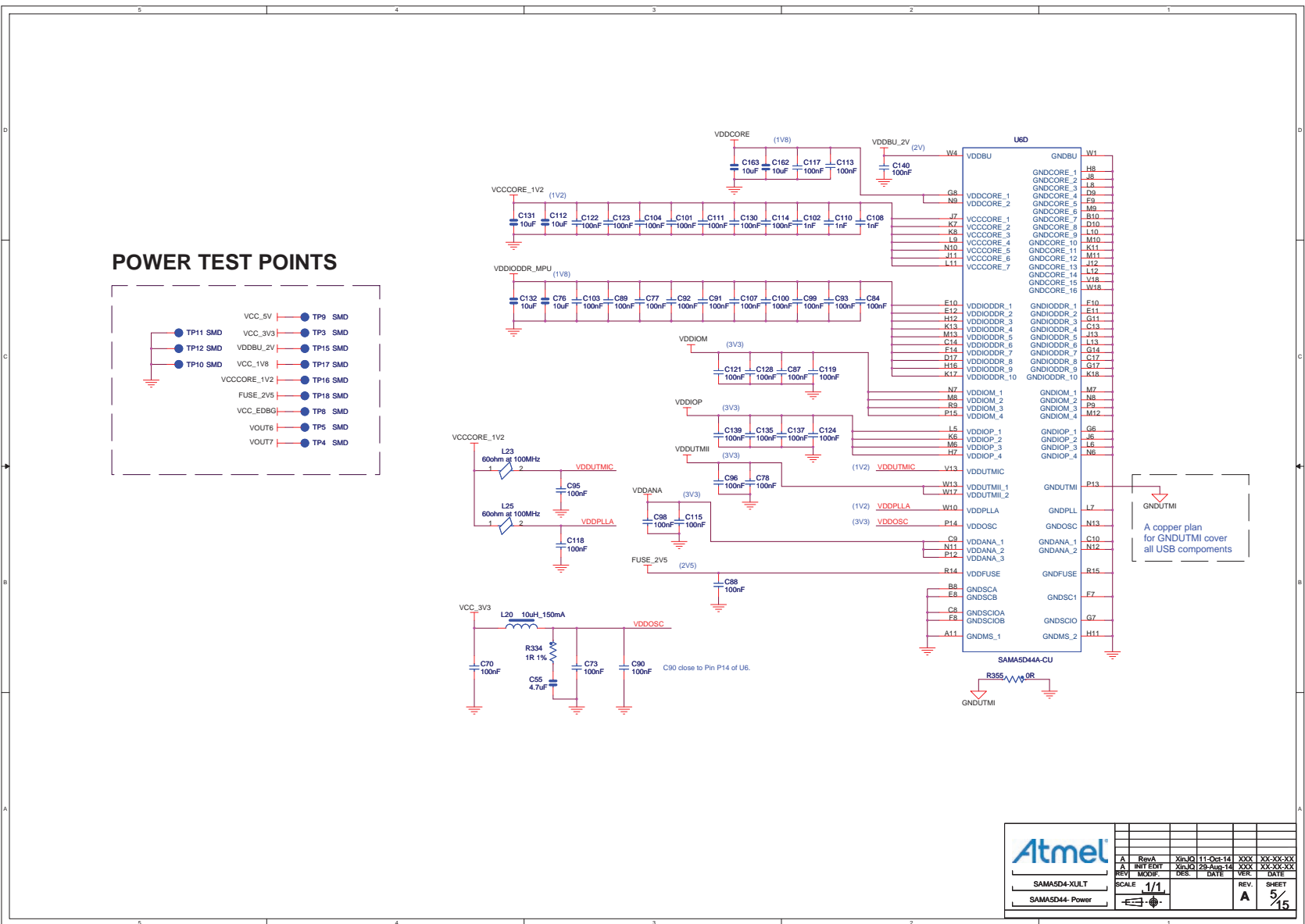

Atmel									
A	RevA	XinIQ	11-4-Oct-14	XXX	XX-XX-XX				
A	INT EDRY	XinIQ	29-Aug-14	XXX	XX-XX-XX				
REV	MODIF.	DES.	DATE	VER.	DATE				
SAMA5D4-XULT		SCALE	1/1						
SAMA5D44 - Power				REV.	A	SHEET	5		15

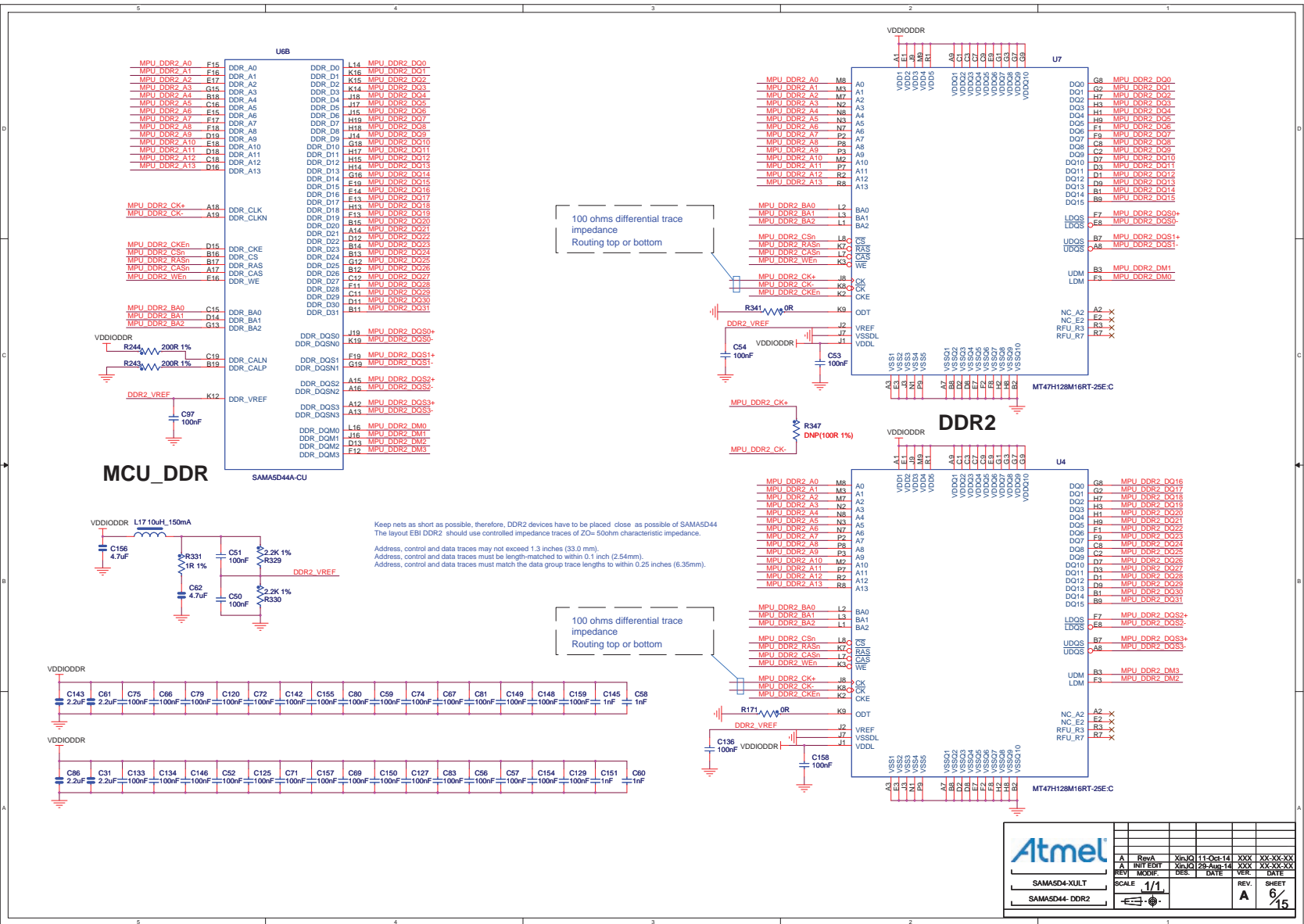

Atmel					
A	RwA	XinJQ	11-Oct-14	XXX	XX-XXX-XX
A	Rev E	XinJQ	29-Aug-14	XXX	XX-XXX-XX
Rev	XXXX	Rev	DATE	Rev	DATE
SAMS44-XULT		SCALE 1/1		REV. SHEET	
SAMS44- DDR2		A		6/15	



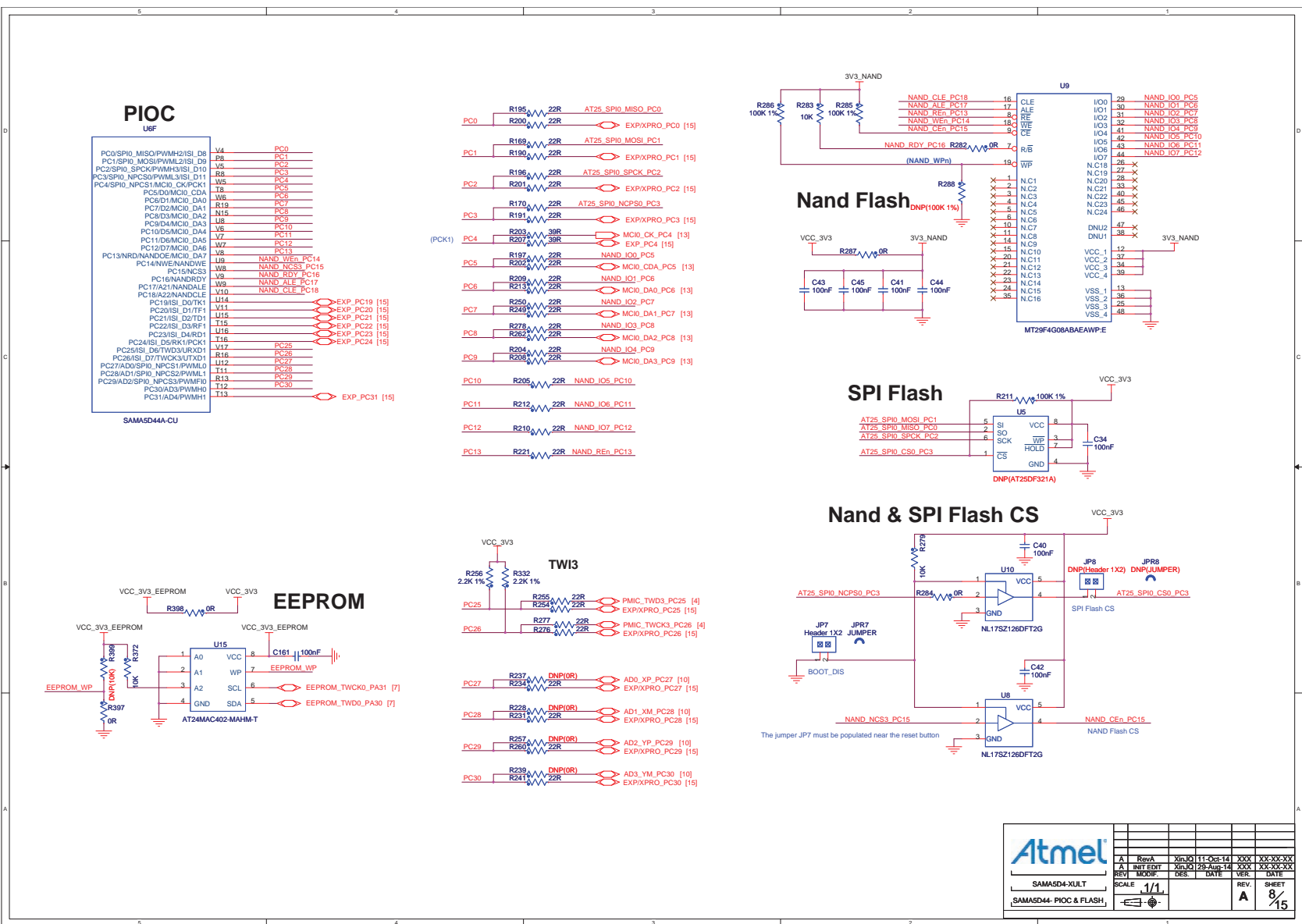

Atmel							
A	RevA	XinJIO	11-05-14	XXX	XXX-XX-XX		
A1	Rev Edr1	XinJIO	29-Aug-14	XXX	XX-XX-XX		
REV	MODIF	REV	DATE	VER	DATE		
SAMA5D4-XULT		SCALE	1/1	REV.	SHEET		
SAMA5D4- PIOC & FLASH				A	8/15		





Figure 4-58. JTAG & USB & DEBUG & LCD

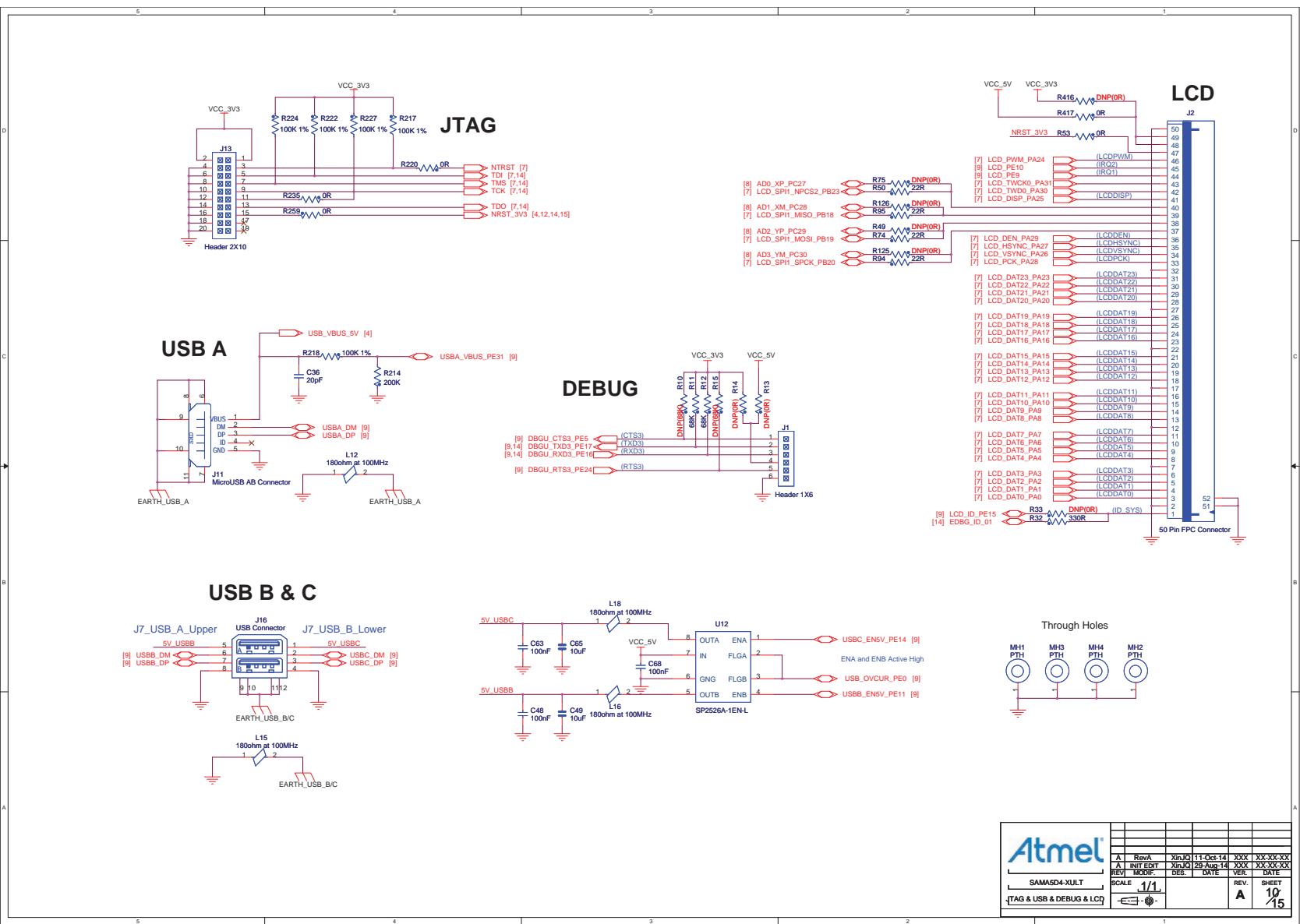

Atmel							
A	RvwA	XinJO	11-Oct-14	XXX	XXX-XXX		
A	Pin Edt	XinJD	29-Aug-14	XXX	XXX-XXX		
REV	NOOP	DES	DATE	VER	DATE		
SAMA5D4-XULT		SCALE	1/1	REV.	SHEET		
JTAG & USB & DEBUG & LCD				A	10	15	

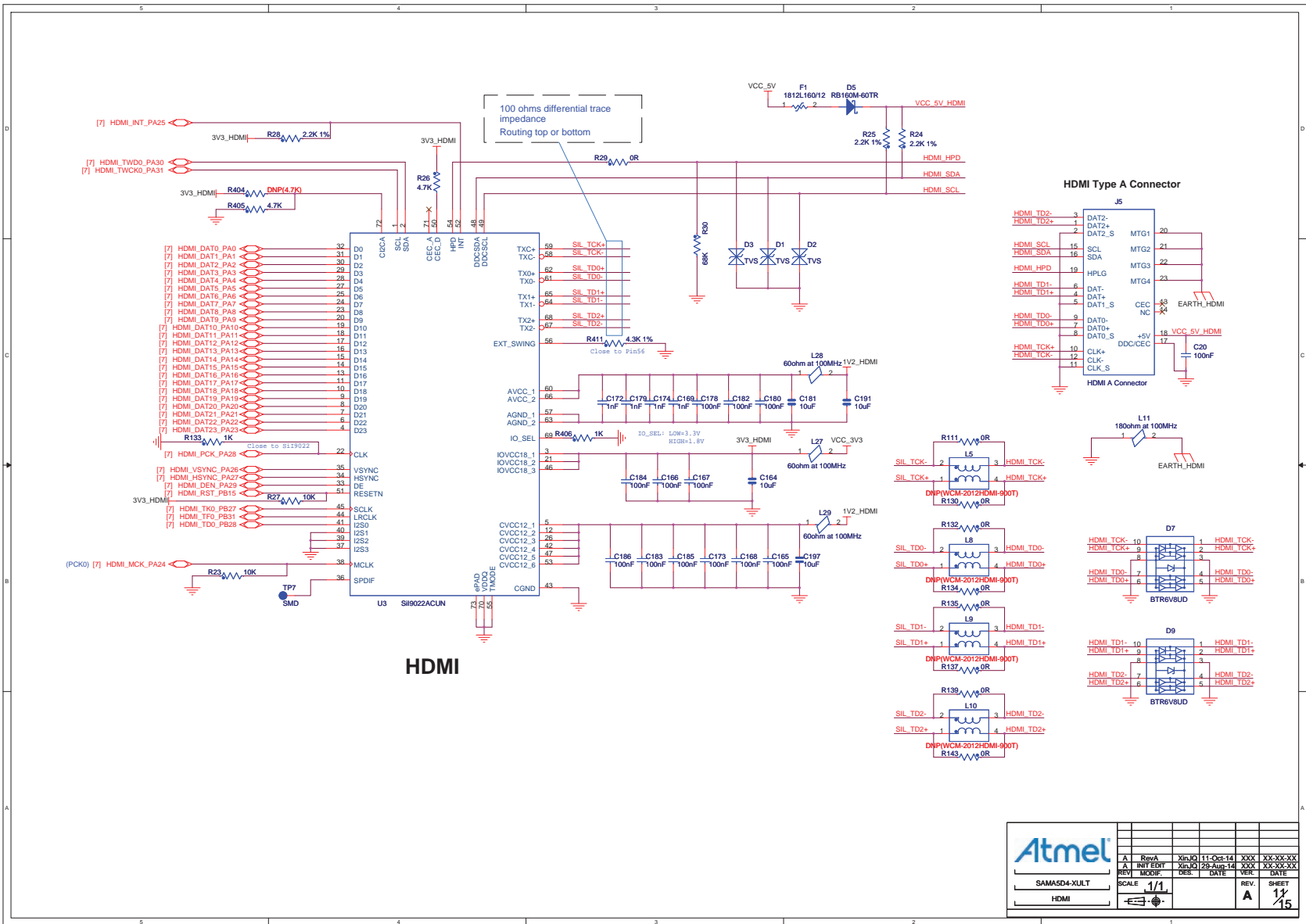
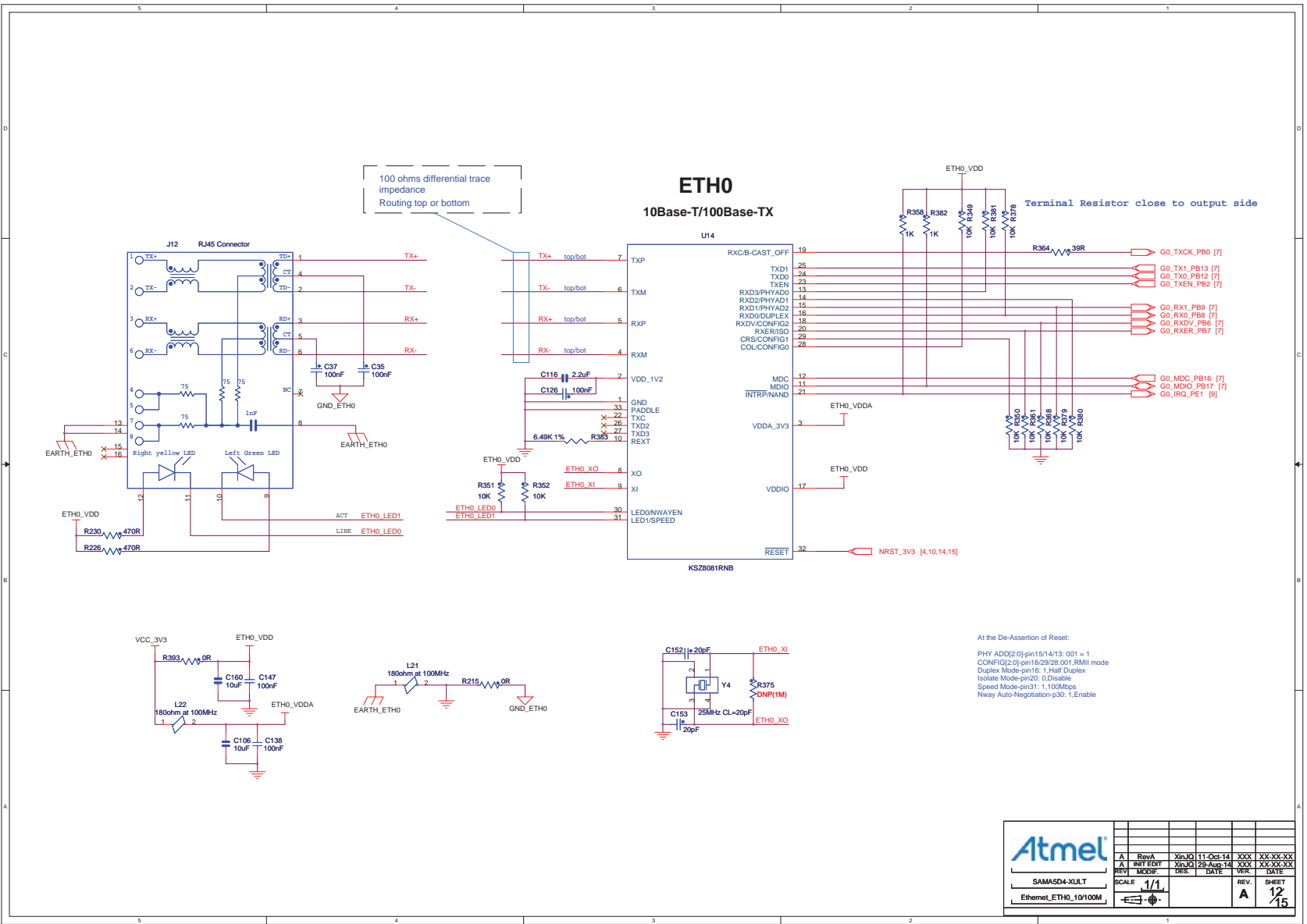
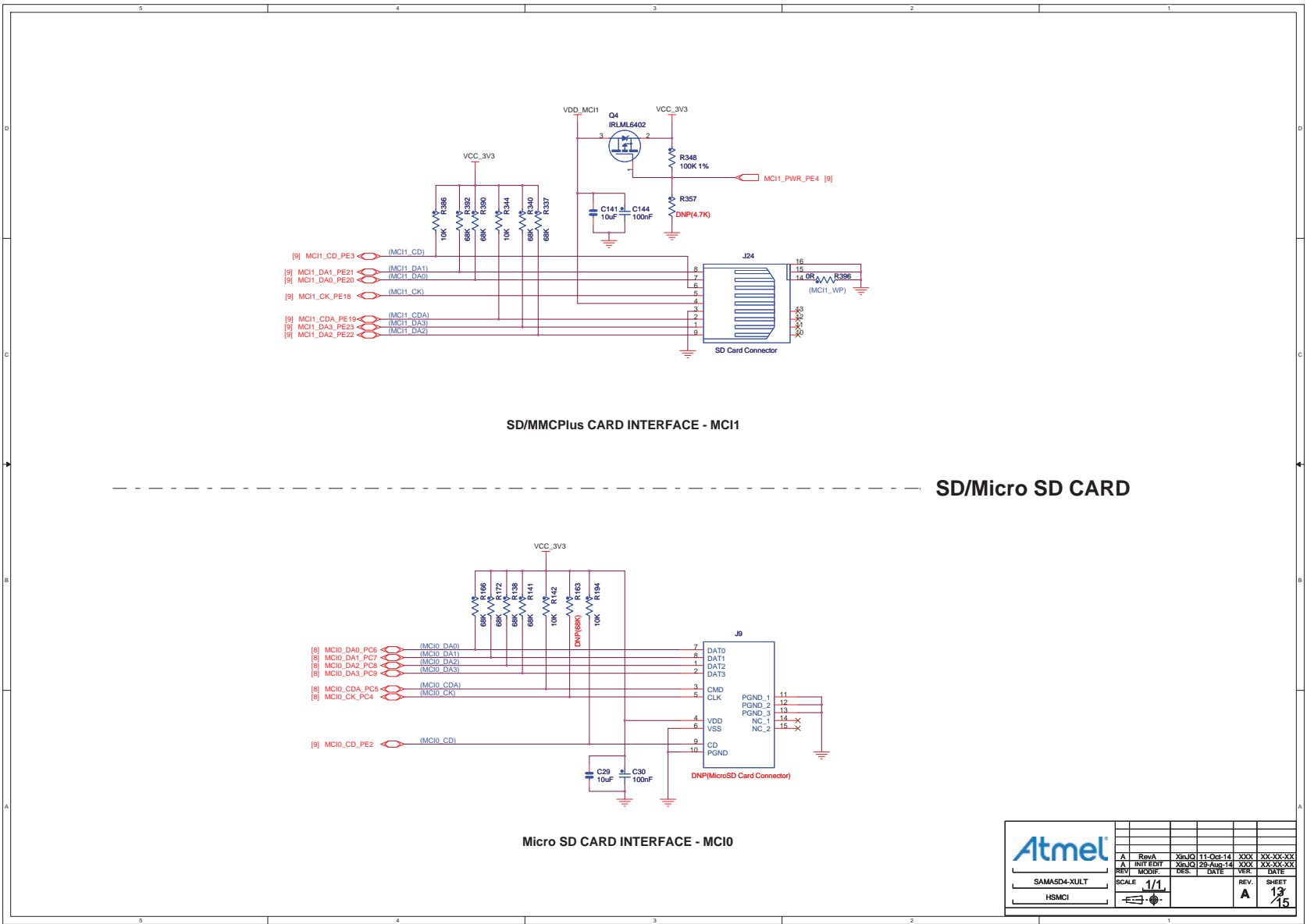

Figure 4-59. HDMI

Atmel					
A	RevA	XinJi	11-Oct-14	XXX	XX-XX-XX
A	RevB	XinJi	25-Aug-14	XXX	XX-XX-XX
REV	MODIF	DES	DATE	VER	DATE
SAMA5D4-XULT		SCALE	1/1	REV.	SHEET
HDMI				A	1/15





Atmel					
A	RevA	XinJIO	11-Oct-14	XXX	XX-XX-XX
A	INIT EDIT	XinJIO	26-Aug-14	XXX	XX-XX-XX
REV	MODIF	DES	DATE	VER	DATE
SAMA5D4-XULT		SCALE	1/1	REV.	SHEET
HSMCI				A	13/15

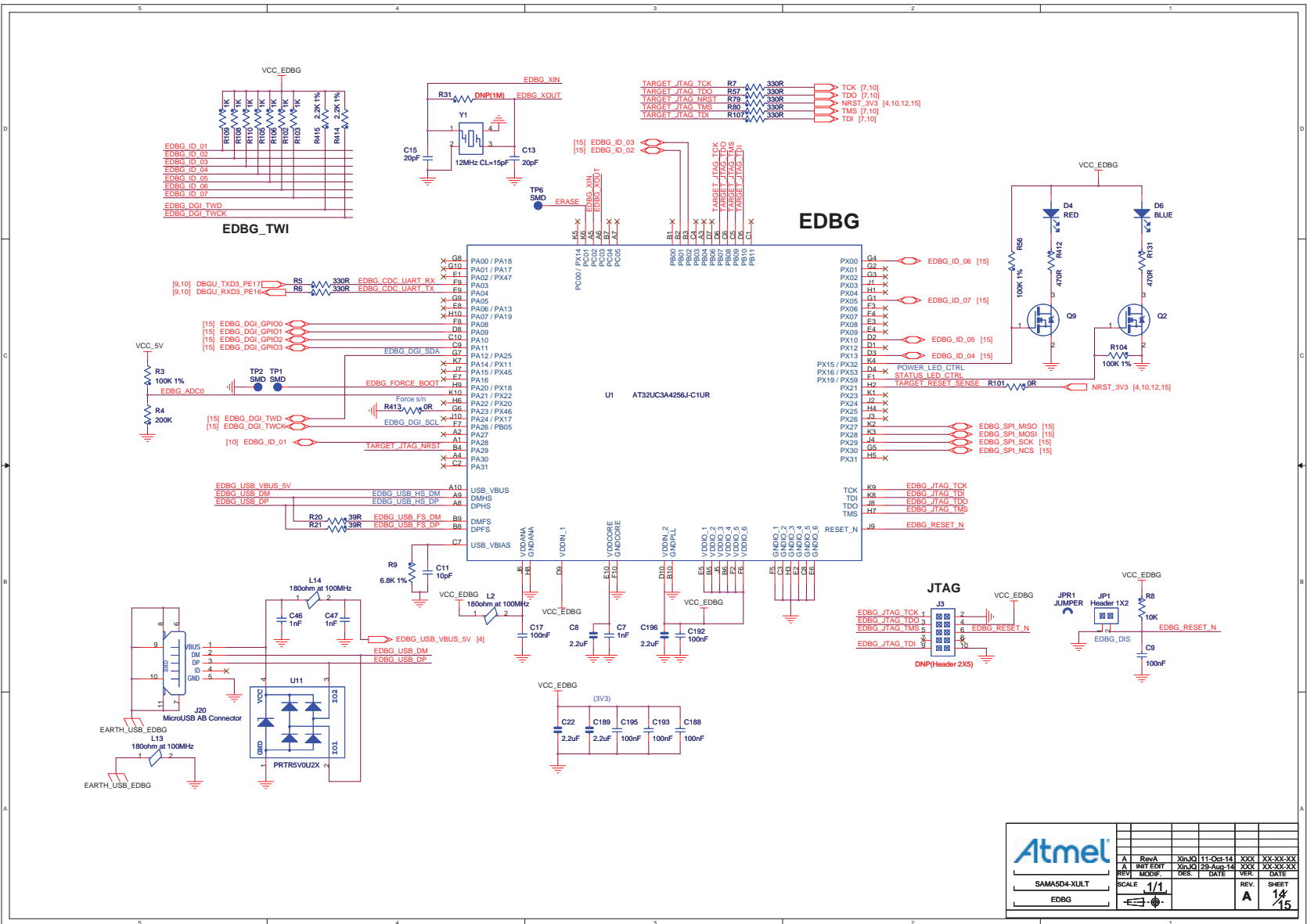

Atmel					
A	RevA	XinJiQ	11-Oct-14	XXX	XX-XX-XX
A1	RevB	XinJiQ	28-Aug-14	XXX	XX-XX-XX
REV	MODIF	DES	DATE	VER	DATE
SAMA5D4-XULT		SCALE	1/1	REV.	SHEET
EDBG				A	1/15





## 5. Revision History

Table 5-1. SAMA5D4 Xplained Ultra User Guide Rev. 44005 Revision History

Doc. Rev.	Changes
44005A	First issue.





Atmel® | Enabling Unlimited Possibilities®



Atmel Corporation    1600 Technology Drive, San Jose, CA 95110 USA    T: (+1)(408) 441.0311    F: (+1)(408) 436.4200    |    [www.atmel.com](http://www.atmel.com)

© 2014 Atmel Corporation. / Rev.: Atmel-44005A-ATARM-SAMA5D4-Xplained-Ultra-User Guide\_07-Nov-14.

Atmel®, Atmel logo and combinations thereof, Enabling Unlimited Possibilities®, QTouch®, and others are registered trademarks or trademarks of Atmel Corporation in U.S. and other countries. ARM®, ARM Connected® logo, and others are the registered trademarks or trademarks of ARM Ltd. Other terms and product names may be trademarks of others.

DISCLAIMER: The information in this document is provided in connection with Atmel products. No license, express or implied, by estoppel or otherwise, to any intellectual property right is granted by this document or in connection with the sale of Atmel products. EXCEPT AS SET FORTH IN THE ATMEL TERMS AND CONDITIONS OF SALES LOCATED ON THE ATMEL WEBSITE, ATMEL ASSUMES NO LIABILITY WHATSOEVER AND DISCLAIMS ANY EXPRESS, IMPLIED OR STATUTORY WARRANTY RELATING TO ITS PRODUCTS INCLUDING, BUT NOT LIMITED TO, THE IMPLIED WARRANTY OF MERCHANTABILITY, FITNESS FOR A PARTICULAR PURPOSE, OR NON-INFRINGEMENT. IN NO EVENT SHALL ATMEL BE LIABLE FOR ANY DIRECT, INDIRECT, CONSEQUENTIAL, PUNITIVE, SPECIAL OR INCIDENTAL DAMAGES (INCLUDING, WITHOUT LIMITATION, DAMAGES FOR LOSS AND PROFITS, BUSINESS INTERRUPTION, OR LOSS OF INFORMATION) ARISING OUT OF THE USE OR INABILITY TO USE THIS DOCUMENT, EVEN IF ATMEL HAS BEEN ADVISED OF THE POSSIBILITY OF SUCH DAMAGES. Atmel makes no representations or warranties with respect to the accuracy or completeness of the contents of this document and reserves the right to make changes to specifications and products descriptions at any time without notice. Atmel does not make any commitment to update the information contained herein. Unless specifically provided otherwise, Atmel products are not suitable for, and shall not be used in, automotive applications. Atmel products are not intended, authorized, or warranted for use as components in applications intended to support or sustain life.

SAFETY-CRITICAL, MILITARY, AND AUTOMOTIVE APPLICATIONS DISCLAIMER: Atmel products are not designed for and will not be used in connection with any applications where the failure of such products would reasonably be expected to result in significant personal injury or death ("Safety-Critical Applications") without an Atmel officer's specific written consent. Safety-Critical Applications include, without limitation, life support devices and systems, equipment or systems for the operation of nuclear facilities and weapons systems. Atmel products are not designed nor intended for use in military or aerospace applications or environments unless specifically designated by Atmel as military-grade. Atmel products are not designed nor intended for use in automotive applications unless specifically designated by Atmel as automotive-grade.