

Customer Information Sheet

DRAWING No.: M80-828XXXX

SHEET 2 OF 2

IF IN DOUBT - ASK

(C)

NOT TO SCALE

THIRD ANGLE PROJECTION

ALL DIMENSIONS IN mm

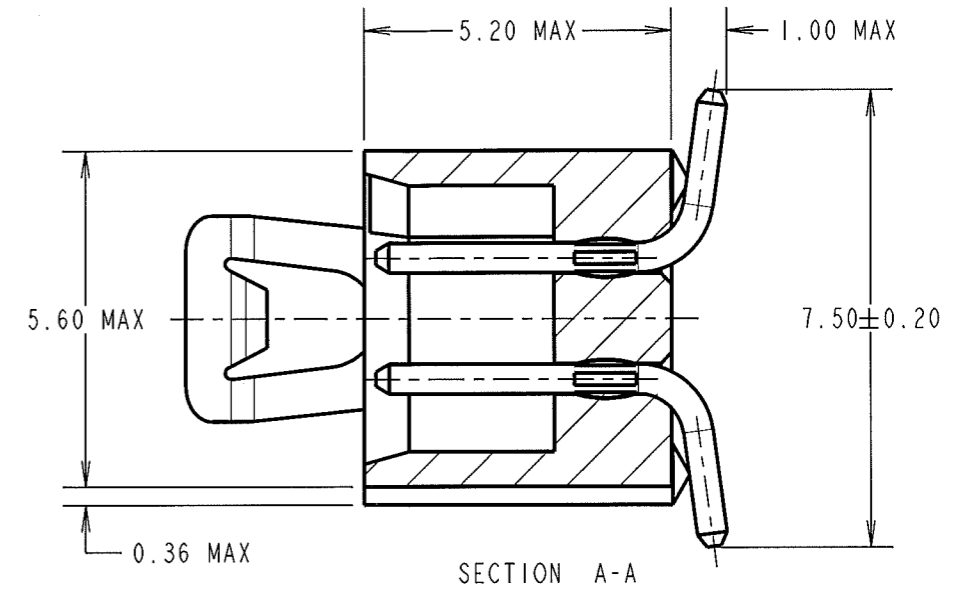
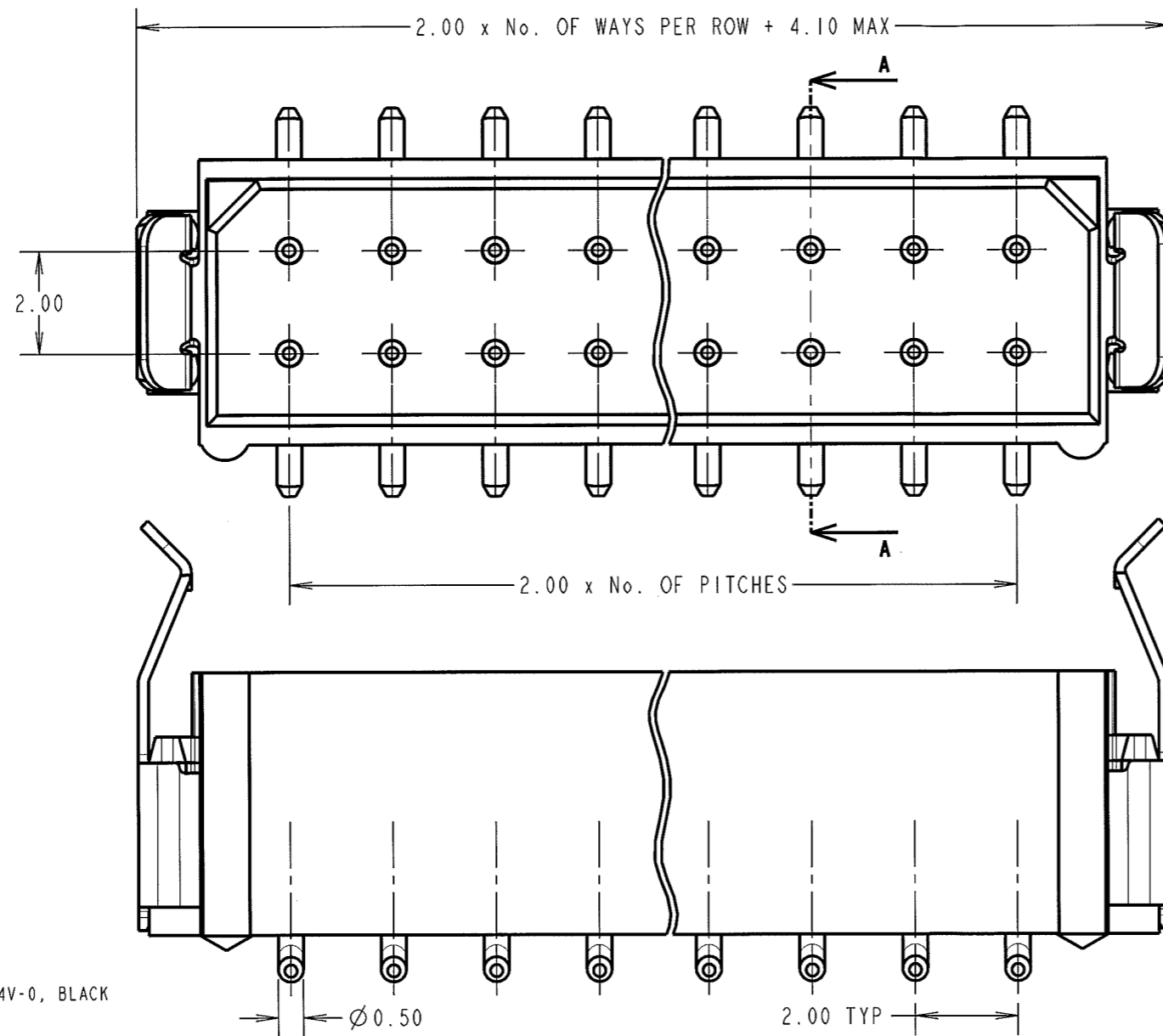

SPECIFICATIONS:

MATERIAL:
 MOULDING = POLYAMIDE 46 UL94V-0, BLACK
 CONTACTS = PHOSPHOR BRONZE
 LATCHES = BERYLLIUM COPPER

FINISH:
CONTACTS:
 06 = 3.0µm 90/10 TIN/LEAD ALL OVER
 22 = 0.75µm GOLD ON CONTACT AREA,
 3.0µm 90/10 TIN/LEAD ON TAILS
 42 = 0.75µm GOLD ON CONTACT AREA,
 3.0µm 100% TIN ON TAILS
 45 = 0.75µm GOLD ALL OVER
 46 = 3.0µm 100% TIN ALL OVER
 LATCH = 1.25µm NICKEL

ELECTRICAL:
 CURRENT RATING AT 25°C = 3.0A MAX
 CURRENT RATING AT 85°C = 2.2A MAX
 WORKING VOLTAGE = 120V AC/DC
 VOLTAGE PROOF = 360V AC/DC
 CONTACT RESISTANCE (INITIAL) = 20 mΩ MAX
 CONTACT RESISTANCE (AFTER CONDITIONING) = 25 mΩ MAX
 INSULATION RESISTANCE (INITIAL) = 1,000 MΩ MIN
 INSULATION RESISTANCE (AFTER CONDITIONING) = 100 MΩ MIN

MECHANICAL:
 DURABILITY = 500 OPERATIONS

ENVIRONMENTAL:
 TEMPERATURE RANGE = -55°C TO +125°C

PACKING:
 TUBE
 FOR COMPLETE SPECIFICATION, SEE COMPONENT SPECIFICATION C005XX (LATEST ISSUE)

RECOMMENDED PCB LAYOUT

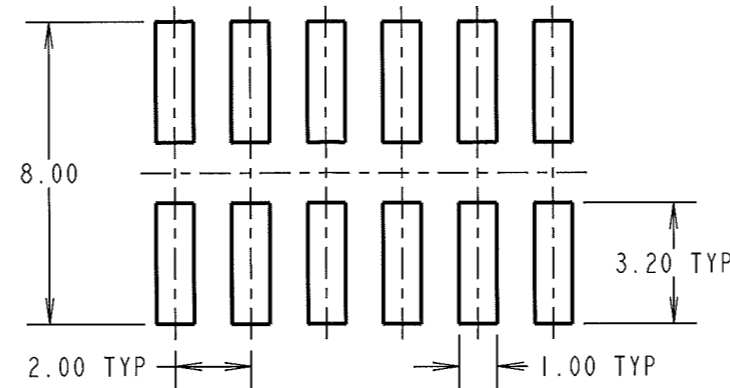

ORDER CODE:

M80-828XXXX

No. OF WAYS _____
 04, 06, 08, 10, 12, 14,
 16, 18, 20, 26, 34, 44

FINISH
 06 - TIN/LEAD
 22 - SELECTIVE GOLD + TIN/LEAD
 42 - SELECTIVE GOLD + 100% TIN
 45 - GOLD
 46 - 100% TIN

SF	8	18.07.08	10098
NAME	ISS.	DATE	C/NOTE
APPROVED: <i>[Signature]</i>			
CHECKED: <i>[Signature]</i>			
DRAWN: S.FLOWER			
CUSTOMER REF.:			
ASSEMBLY DRG:			

HARWIN

HARWIN USA TEL: 603 893 5376 FAX: 603 893 5396 mis@harwin.com	HARWIN Europe (UK) TEL: 023 9231 4545 FAX: 023 9231 4590 mis@harwin.co.uk	HARWIN Asia TEL: +65 6 779 4909 FAX: +65 6 779 3868 mis@harwin.com.sg
--	--	--

THIS DRAWING AND ANY INFORMATION OR DESCRIPTIVE MATTER SET OUT HEREON ARE CONFIDENTIAL AND COPYRIGHT PROPERTY OF THE HARWIN GROUP AND MUST NOT BE DISCLOSED, LOANED, COPIED OR USED FOR MANUFACTURING, TENDERING OR FOR ANY OTHER PURPOSE WITHOUT THEIR WRITTEN PERMISSION.

TOLERANCES
 X. = ±1mm
 X.X = ±0.25mm
 X.XX = ±0.10mm
 X.XXX = ±0.01mm
 ANGLES = ±5°
 UNLESS STATED

MATERIAL:
 M80-826XXXX
 (SEE ABOVE)
FINISH: SEE ABOVE
S/AREA: mm²

TITLE: DATAMATE DIL
 VERTICAL SMT PLUG
 ASSEMBLY - LATCHED
DRAWING NUMBER:
M80-828XXXX

SHT
 2 OF 2