

# Target Board Kit S3A6 (TB-S3A6)

User's Manual

Renesas Synergy™ Platform  
Synergy Tools & Kits  
Kits: TB-S3A6 v1.0

All information contained in these materials, including products and product specifications, represents information on the product at the time of publication and is subject to change by Renesas Electronics Corp. without notice. Please review the latest information published by Renesas Electronics Corp. through various means, including the Renesas Electronics Corp. website (<http://www.renesas.com>).

## Notice

1. Descriptions of circuits, software and other related information in this document are provided only to illustrate the operation of semiconductor products and application examples. You are fully responsible for the incorporation or any other use of the circuits, software, and information in the design of your product or system. Renesas Electronics disclaims any and all liability for any losses and damages incurred by you or third parties arising from the use of these circuits, software, or information.
  2. Renesas Electronics hereby expressly disclaims any warranties against and liability for infringement or any other claims involving patents, copyrights, or other intellectual property rights of third parties, by or arising from the use of Renesas Electronics products or technical information described in this document, including but not limited to, the product data, drawings, charts, programs, algorithms, and application examples.
  3. No license, express, implied or otherwise, is granted hereby under any patents, copyrights or other intellectual property rights of Renesas Electronics or others.
  4. You shall not alter, modify, copy, or reverse engineer any Renesas Electronics product, whether in whole or in part. Renesas Electronics disclaims any and all liability for any losses or damages incurred by you or third parties arising from such alteration, modification, copying or reverse engineering.
  5. Renesas Electronics products are classified according to the following two quality grades: "Standard" and "High Quality". The intended applications for each Renesas Electronics product depends on the product's quality grade, as indicated below.
    - "Standard": Computers; office equipment; communications equipment; test and measurement equipment; audio and visual equipment; home electronic appliances; machine tools; personal electronic equipment; industrial robots; etc.
    - "High Quality": Transportation equipment (automobiles, trains, ships, etc.); traffic control (traffic lights); large-scale communication equipment; key financial terminal systems; safety control equipment; etc.
- Unless expressly designated as a high reliability product or a product for harsh environments in a Renesas Electronics data sheet or other Renesas Electronics document, Renesas Electronics products are not intended or authorized for use in products or systems that may pose a direct threat to human life or bodily injury (artificial life support devices or systems; surgical implantations; etc.), or may cause serious property damage (space system; undersea repeaters; nuclear power control systems; aircraft control systems; key plant systems; military equipment; etc.). Renesas Electronics disclaims any and all liability for any damages or losses incurred by you or any third parties arising from the use of any Renesas Electronics product that is inconsistent with any Renesas Electronics data sheet, user's manual or other Renesas Electronics document.
6. When using Renesas Electronics products, refer to the latest product information (data sheets, user's manuals, application notes, "General Notes for Handling and Using Semiconductor Devices" in the reliability handbook, etc.), and ensure that usage conditions are within the ranges specified by Renesas Electronics with respect to maximum ratings, operating power supply voltage range, heat dissipation characteristics, installation, etc. Renesas Electronics disclaims any and all liability for any malfunctions, failure or accident arising out of the use of Renesas Electronics products outside of such specified ranges.
  7. Although Renesas Electronics endeavors to improve the quality and reliability of Renesas Electronics products, semiconductor products have specific characteristics, such as the occurrence of failure at a certain rate and malfunctions under certain use conditions. Unless designated as a high reliability product or a product for harsh environments in a Renesas Electronics data sheet or other Renesas Electronics document, Renesas Electronics products are not subject to radiation resistance design. You are responsible for implementing safety measures to guard against the possibility of bodily injury, injury or damage caused by fire, and/or danger to the public in the event of a failure or malfunction of Renesas Electronics products, such as safety design for hardware and software, including but not limited to redundancy, fire control and malfunction prevention, appropriate treatment for aging degradation or any other appropriate measures. Because the evaluation of microcomputer software alone is very difficult and impractical, you are responsible for evaluating the safety of the final products or systems manufactured by you.
  8. Please contact a Renesas Electronics sales office for details as to environmental matters such as the environmental compatibility of each Renesas Electronics product. You are responsible for carefully and sufficiently investigating applicable laws and regulations that regulate the inclusion or use of controlled substances, including without limitation, the EU RoHS Directive, and using Renesas Electronics products in compliance with all these applicable laws and regulations. Renesas Electronics disclaims any and all liability for damages or losses occurring as a result of your noncompliance with applicable laws and regulations.
  9. Renesas Electronics products and technologies shall not be used for or incorporated into any products or systems whose manufacture, use, or sale is prohibited under any applicable domestic or foreign laws or regulations. You shall comply with any applicable export control laws and regulations promulgated and administered by the governments of any countries asserting jurisdiction over the parties or transactions.
  10. It is the responsibility of the buyer or distributor of Renesas Electronics products, or any other party who distributes, disposes of, or otherwise sells or transfers the product to a third party, to notify such third party in advance of the contents and conditions set forth in this document.
  11. This document shall not be reprinted, reproduced or duplicated in any form, in whole or in part, without prior written consent of Renesas Electronics.
  12. Please contact a Renesas Electronics sales office if you have any questions regarding the information contained in this document or Renesas Electronics products.

(Note1) "Renesas Electronics" as used in this document means Renesas Electronics Corporation and also includes its directly or indirectly controlled subsidiaries.

(Note2) "Renesas Electronics product(s)" means any product developed or manufactured by or for Renesas Electronics.

(Rev.4.0-1 November 2017)

## Corporate Headquarters

TOYOSU FORESIA, 3-2-24 Toyosu,  
Koto-ku, Tokyo 135-0061, Japan  
[www.renesas.com](http://www.renesas.com)

## Trademarks

Renesas and the Renesas logo are trademarks of Renesas Electronics Corporation. All trademarks and registered trademarks are the property of their respective owners.

## Contact information

For further information on a product, technology, the most up-to-date version of a document, or your nearest sales office, please visit:  
[www.renesas.com/contact/](http://www.renesas.com/contact/).

## Renesas Synergy™ Target Board Kit S3A6 (TB-S3A6) Disclaimer

By using this TB-S3A6, the user accepts the following terms, which are in addition to, and control in the event of disagreement, with Renesas' General Terms and Conditions available at <https://www.renesas.com/en-us/legal/disclaimer.html>.

The TB-S3A6 is not guaranteed to be error free, and the entire risk as to the results and performance of the TB-S3A6 is assumed by the User. The TB-S3A6 is provided by Renesas on an "as is" basis without warranty of any kind whether express or implied, including but not limited to the implied warranties of satisfactory quality, fitness for a particular purpose, title, and non-infringement of intellectual property rights with regard to the TB-S3A6. Renesas expressly disclaims all such warranties.

Renesas does not consider the TB-S3A6 a finished product and therefore the TB-S3A6 may not yet comply with some requirements applicable to finished products, including, but not limited to recycling (WEEE), CE, UL, restricted substances (ROHS), FCC, FEE, and electromagnetic compatibility regulations. Renesas or its affiliates shall in no event be liable for any loss of profit, loss of data, loss of contract, loss of business, damage to reputation or goodwill, any economic loss, any reprogramming or recall costs (whether the foregoing losses are direct or indirect) nor shall Renesas or its affiliates be liable for any other direct or indirect special, incidental or consequential damages arising out of or in relation to the use of this TB-S3A6, even if Renesas or its affiliates have been advised of the possibility of such damages.

Renesas has used reasonable care in preparing the information included in this document, but Renesas does not warrant that such information is error free nor does Renesas guarantee an exact match for every application or parameter to part numbers designated by other vendors listed herein. The information provided in this document is intended solely to enable the use of Renesas products. No express or implied license to any intellectual property right is granted by this document or in connection with the sale of Renesas products. Renesas reserves the right to make changes to specifications and product descriptions at any time without notice. Renesas assumes no liability for any damages incurred by you resulting from errors in or omissions from the information included herein. Renesas cannot verify, and assumes no liability for, the accuracy of information available on another company's website.

## Precautions

This Renesas Synergy™ Target Board Kit is only intended for use in a laboratory environment under ambient temperature and humidity conditions. A safe separation distance should be used between this and any sensitive equipment. Its use outside the laboratory, classroom, study area, or similar such area invalidates conformity with the protection requirements of the Electromagnetic Compatibility Directive and could lead to prosecution.

The product generates, uses, and can radiate radio frequency energy and may cause harmful interference to radio communications. There is no guarantee that interference will not occur in a particular installation. If this equipment causes harmful interference to radio or television reception, which can be determined by turning the equipment off or on, you are encouraged to try to correct the interference by one or more of the following measures:

- Ensure attached cables do not lie across the equipment.
- Reorient the receiving antenna.
- Increase the distance between the equipment and the receiver.
- Connect the equipment into an outlet on a circuit different from that which the receiver is connected.
- Power down the equipment when not in use.
- Consult the dealer or an experienced radio/TV technician for help.

Note: It is recommended that wherever possible shielded interface cables are used.

The product is potentially susceptible to certain EMC phenomena. To mitigate against them it is recommended that the following measures be undertaken:

- The user is advised that mobile phones should not be used within 10 m of the product when in use.
- The user is advised to take ESD precautions when handling the equipment.

The Renesas Synergy™ Target Board Kit does not represent an ideal reference design for an end product and does not fulfill the regulatory standards for an end product.

## Renesas Synergy™ Platform

**Target Board Kit S3A6 (TB-S3A6)**
**Contents**

1. Overview .....	3
2. Kit Contents.....	6
3. Getting Started with Embedded Application Development on TB-S3A6.....	6
4. TB-S3A6 Hardware Details.....	6
4.1 Jumpers and DIP Switch Settings.....	6
4.1.1 Copper Jumpers.....	6
4.1.2 Default Board Configuration.....	7
5. Hardware Layout .....	8
5.1 System Block Diagram .....	8
5.2 Power Requirements.....	9
5.2.1 Power Supply Options.....	9
5.2.1.1 Option 1: Debug USB (default) .....	9
5.2.1.2 Option 2: Test Points TP3 and TP4 .....	9
5.2.1.3 Option 3: Test Points TP1 and TP2 .....	10
5.2.1.4 Option 4: Pin Headers .....	10
5.2.2 Powering up the Board.....	11
5.2.3 Battery Supply Configuration.....	11
5.2.4 Measuring Current Consumption .....	11
5.3 Main Components .....	12
5.4 Connectivity and Settings.....	13
5.4.1 Device USB .....	13
5.4.2 Debug USB.....	14
5.4.3 JTAG/SWD.....	14
5.4.4 LEDs.....	15
5.4.5 Switches .....	16
5.4.6 PMOD A .....	17
5.4.7 PMOD B .....	18
5.4.8 User Capacitive Touch Button.....	18
5.5 Pin Headers.....	19
5.5.1 Pin Header J1.....	21
5.5.2 Pin Header J2.....	22
5.5.3 Pin Header J3.....	23
5.5.4 Pin Header J4.....	24

---

5.6	Additional Features.....	24
5.6.1	Analog Reference Voltages.....	24
5.6.2	On-Board Clock Crystals.....	25
5.6.3	User Potentiometer .....	25
5.6.4	Boot Configuration.....	26
5.6.5	Miscellaneous Signals.....	26
5.6.5.1	AVCC0/AVSS0.....	26
5.6.5.2	VCL.....	26
5.6.5.3	VCC_USB_LDO.....	26
5.6.5.4	VCC_USB .....	26
5.6.5.5	Signal P205.....	27
6.	Electrical Schematics.....	28
7.	Mechanical Drawing .....	32
8.	Certifications.....	33
	Revision History.....	35

## 1. Overview

The Target Board Kit S3A6 (TB-S3A6) enables developers to get started with initial firmware development and to evaluate the Synergy Software Package (SSP) on the S3A6 MCU Group.

- Renesas Synergy™ S3A6 Microcontroller Group
  - R7FS3A6783A01CFP
  - 100-pin Low Profile Quad Flat Pack (LQFP) package
  - 48 MHz Arm® Cortex®-M4 core with Floating Point Unit (FPU)
  - 32 KB SRAM
  - 256 KB code flash memory
  - 8 KB data flash memory
- Connectivity
  - A Device USB connector for the Main MCU
  - SEGGER J-Link® On-Board (OB) interface for debugging and programming of the S3A6 MCU. A 10-pin JTAG/SWD interface is also provided for connecting optional external debuggers and programmers.
  - Two PMOD connectors, allowing use of appropriate PMOD compliant peripheral plug-in modules for rapid prototyping
  - Pin headers for access to power and signals for the Main MCU
- Multiple clock sources
  - Main MCU oscillator crystals, providing precision 12.000 MHz and 32,768 Hz reference clocks
  - Additional low-precision clocks are available internal to the Main MCU
- MCU reset push-button switch
- MCU boot configuration jumper
- General purpose I/O ports
  - One jumper to allow measuring of Main MCU current
  - Copper jumpers on PCB bottom side for configuration and access to selected MCU signals
- Operating voltage
  - External 5 V input through the Debug USB connector supplies the on-board power regulator to power the Target Board logic and interfaces. External 5 V or 3.3 V may also be supplied through alternate locations on the Target Board.
- A two-color board status LED indicating availability of regulated power and connection status of the J-Link interface
- A red User LED, controlled by the Main MCU firmware
- A User Push-Button switch, User Capacitive Touch Sensor (button), and an optional User Potentiometer, all of which are controlled by the Main MCU firmware

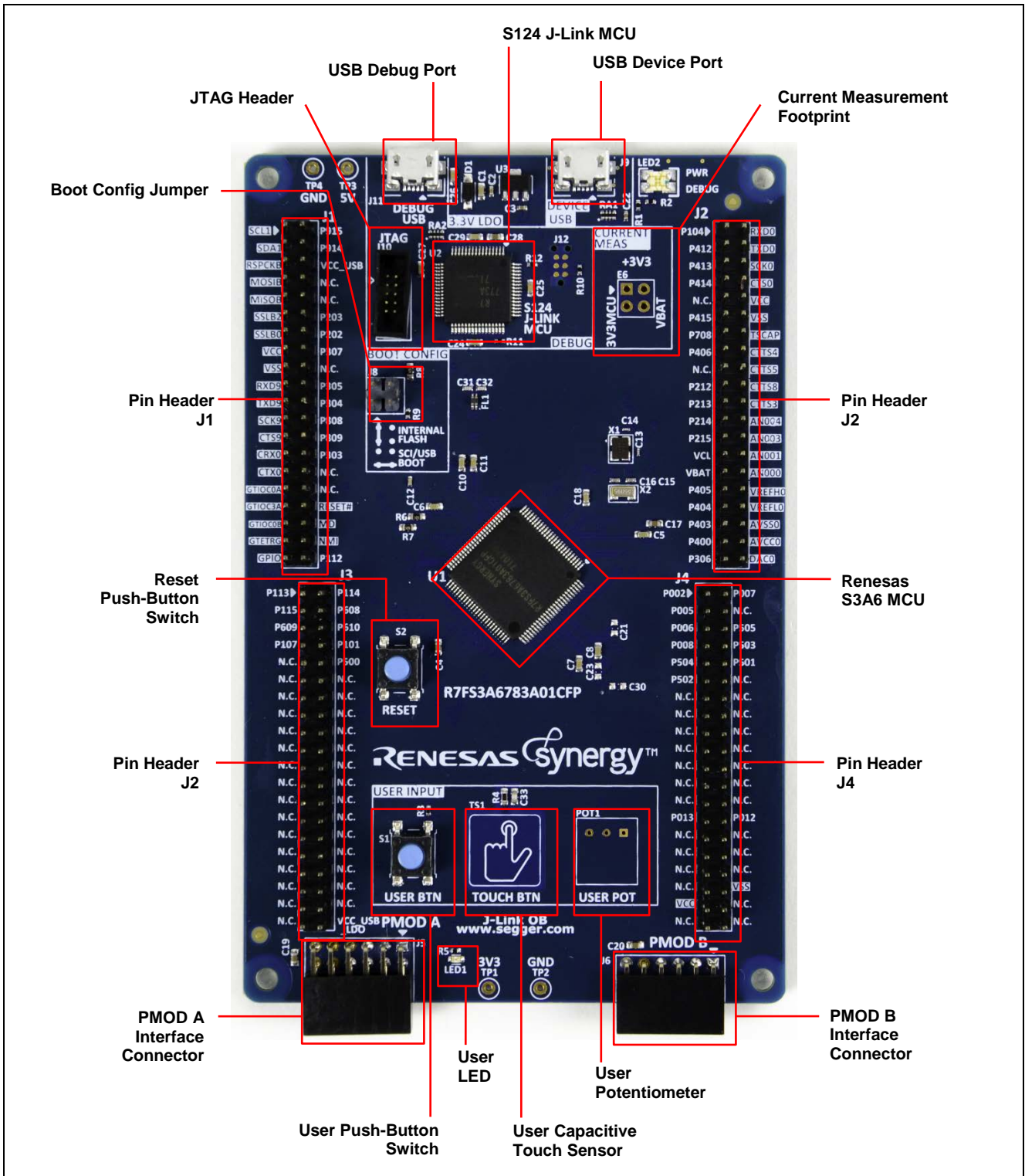

Figure 1. TB-S3A6 Top Side



## 2. Kit Contents

The following components are included in the Target Board Kit S3A6 (TB-S3A6):

- 1x TB-S3A6 board
- 1x USB Type-A to Micro-B cable

## 3. Getting Started with Embedded Application Development on TB-S3A6

To develop and execute embedded applications on the TB-S3A6 using the Synergy Platform, Synergy Software Package and development tools are required to be installed on your computer.

### Step 1: Create My Renesas Account (if you do not have one already)

You need a **My Renesas** account to download software, development tools, and application projects. Log in to or Sign up for a **My Renesas** account at [www.update.renesas.com/SSO/login](http://www.update.renesas.com/SSO/login).

### Step 2: Download and Install Synergy Software Package and Development Tools

The Synergy Software Package, J-Link USB drivers, and one of the two supported tool chains are bundled and available as single downloadable file as follows:

- IAR Platform Installer** installs Synergy Software Package and IAR Embedded Workbench® for Renesas Synergy™ IDE with IAR compiler and J-Link USB drivers.  
Download from [www.renesas.com/synergy/ewsynergy](http://www.renesas.com/synergy/ewsynergy).
- e<sup>2</sup> studio Platform Installer** installs Synergy Software Package and e<sup>2</sup> studio for Synergy IDE with IAR compiler and J-Link USB drivers.  
Download from [www.renesas.com/synergy/e2studio](http://www.renesas.com/synergy/e2studio).

Note: The TB-S3A6 uses J-Link® On-board (OB) debug interface. While J-Link drivers are necessary to establish debug connection between the host PC and the TB-S3A6, they are not required to run the Out-of-Box (OoB) Demonstration (Blinky) Application that the TB-S3A6 comes pre-programmed with. Refer to the *TB-S3A6 Quick Start Guide* for more details.

### Step 3: Explore Existing Application Projects for the TB-S3A6

Renesas provides several application projects to demonstrate different capabilities of the S3A6 MCU Group. These application projects can also serve as a good starting point for you to develop your custom applications. Application projects available for the TB-S3A6 are listed at <http://www.renesas.com/synergy/tb-s3a6>.

- Notes:
1. Every application project includes the project files, an application note, and instructions to import the application project.
  2. On downloading the application project from the website to your computer, the application projects have to be built using one of the two supported tool chains before they can be downloaded on to the TB-S3A6 board.

## 4. TB-S3A6 Hardware Details

### 4.1 Jumpers and DIP Switch Settings

#### 4.1.1 Copper Jumpers

There are two types of copper jumpers, designated **trace-cut** and **solder-bridge**.

A **trace-cut jumper** is provided with a narrow copper trace connecting its pads. The silk screen overlay printing around a trace-cut jumper is a solid box. To isolate the pads, cut the trace between pads adjacent to each pad then remove the connecting copper foil either mechanically or with the assistance of heat. Once the etched copper trace is removed, the trace-cut jumper is turned into a solder-bridge jumper for any later changes.

A **solder-bridge jumper** is provided with two isolated pads that may be joined together by one of three methods:

- Solder may be applied to both pads to develop a bulge on each and the bulges joined by touching a soldering iron across the two pads.

- A small wire may be placed across the two pads and soldered in place.
- A SMT resistor, size 0805, 0603, or 0402, may be placed across the two pads and soldered in place. A zero-ohm resistor shorts the pads together.

The silk screen overlay printing around a solder-bridge jumper is a box with a gap in the lines adjacent to the isolation region between the pads.

For any copper jumper, the connection is considered **closed** if there is an electrical connection between the pads (default for trace-cut jumpers). The connection is considered **open** if there is no electrical connection between the pads (default for the solder-bridge jumpers).

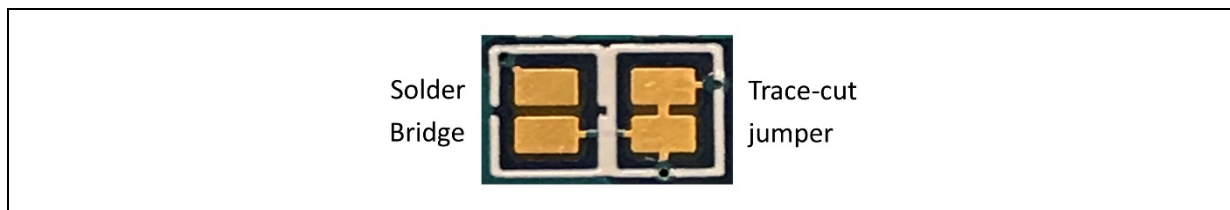

Figure 3. Copper Jumpers

### 4.1.2 Default Board Configuration

The following table describes the default settings for each jumper on the TB-S3A6. This includes traditional pin jumpers (Jx designation) and copper jumpers (Ex designation).

The Circuit Group for each jumper is the designation found in the board schematic. See section 6, Electrical Schematics. Functional details for many of the listed jumpers may be found in section 5.4, Connectivity and Settings and section 5.6, Additional Features.

Table 1. Default Jumper Settings

Location	Circuit Group	Default Open/Closed	Function
J8	MCU Mode Config	Shunt on pins 1-2	Sets the MCU Mode to boot from Internal Flash
E18	12M XTAL	Open	Connects signal P213 to MCU
E19		Open	Connects signal P212 to MCU
E23		Closed	Connects 12.000 MHz Crystal to MCU
E24		Closed	Connects 12.000 MHz Crystal to MCU
E1	3.3 V Linear Regulator	Closed	Alternate 3.3 V source (+3V3JLOB)
E22	32K XTAL	Open	Connects signal P215 to MCU
E25		Closed	Connects 32.768 kHz Crystal to MCU
E26		Closed	Connects 32.768 kHz Crystal to MCU
E27		Open	Connects signal P214 to MCU
E10	AVCC0-> +3V3MCU	Closed	Connects +3V3MCU to AVCC0
E11	AVSS0->GND	Closed	Connects AVSS0 to Ground
E2	Capacitive Touch-Button	Closed	Enable/Disable Capacitive Touch-Button
E5		Open	Connects signal P115J to Capacitive Touch-Button
E28	EXT VCL and VCL CAP	Open	Connects VCL to MCU
E29		Closed	Connects MCU pin 15 (VCL) to capacitor
E32	J-Link	Closed	Connects the S124 MCU to the J-Link signal JLED
E33		Closed	Connects the S124 MCU to the J-Link signal RESET#
E34		Closed	Connects the S124 MCU to the J-Link signal TDO(/SWO) P109
E37		Closed	Connects the S124 MCU to the J-Link signal P108/SWDIO
E38		Closed	Connects the S124 MCU to the J-Link signal P300/SWCLK
E35	J-Link® OB USB	Closed	Connects the J-Link OB USB 5V input to the primary 5V->3.3V voltage regulator

Location	Circuit Group	Default Open/Closed	Function
E31	JTAG Connector	Open	JTAG Ground Detect. Connects the JTAG connector pin 9 to Ground.
E13	LDO and VCC USB	Open	Connects VCC_USB_LDO to MCU pin 41
E14		Open	Connects VCC_USB_LDO to MCU pin 40
E7		Closed	Connects +3V3MCU to MCU pin 41
E8		Closed	Connects +3V3MCU to MCU pin 40
E12	P205 or TSCAP-A	Open	Connects MCU pin 43 to signal P205
E15		Closed	Connects MCU pin 43 to capacitor
E30	USB Device Interface	Closed	Connects the Device USB 5V input to the MCU
E16	USB FS	Closed	Connects MCU pin 38 to signal USB_N
E17		Closed	Connects MCU pin 39 to signal USB_P
E20		Open	Connects MCU pin 39 to signal USBPH_P
E21		Open	Connects MCU pin 38 to signal USBPH_N
E3		User LED	Closed
E36	User Potentiometer	Open	Enable/Disable User Potentiometer
E4	User Push-Button	Closed	Enable/Disable User Push-Button switch
E6	VBAT +3V3_MCU	Closed	Dual Jumper. Pins 1-3 connect +3V3 to +3V3MCU. Pins 2-4 connect +3V3 to VBAT.

## 5. Hardware Layout

### 5.1 System Block Diagram

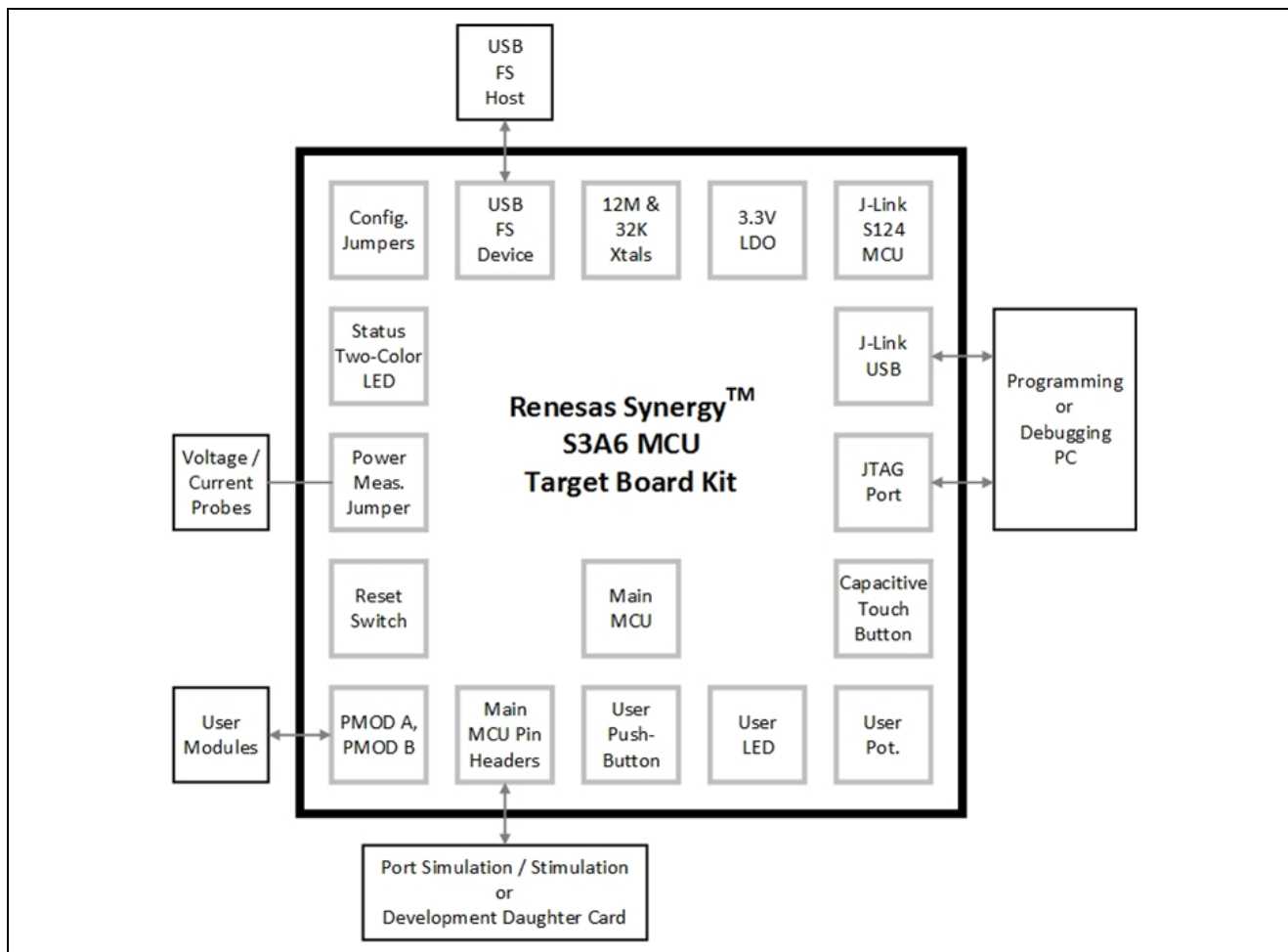

Figure 4. TB-S3A6 Block Diagram

## 5.2 Power Requirements

TB-S3A6 is designed for 3.3 V operation. This also means that 5 V PMOD devices cannot be used together with the TB-S3A6 unless they are powered separately.

The total current available from the LDO regulator for all connected circuits is 600 mA or less, depending on the 5 V power source used.

### 5.2.1 Power Supply Options

TB-S3A6 can be powered in several different ways as described in this section.

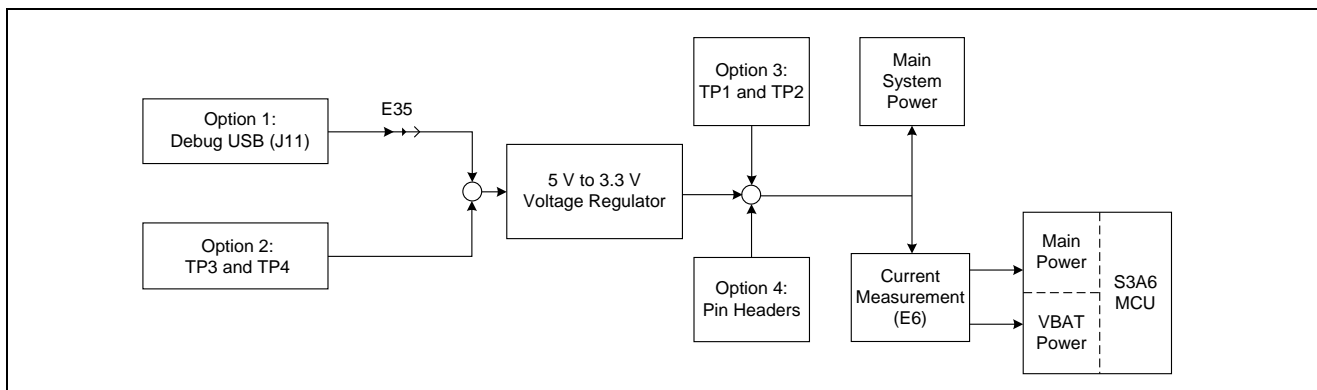

Figure 5. Power Supply Options

#### 5.2.1.1 Option 1: Debug USB (default)

The default power source is 5 V, supplied from an external USB host to the USB Debug connector labelled **DEBUG USB** on the top surface of the board. A low drop-out regulator (LDO) is used to convert the 5 V signal to 3.3 V, which then is used to power the MCU and any connected devices.

Copper jumper E35 selects the source for the primary power input to the LDO regulator. By default, this jumper is configured to provide power through the Debug USB connector. Copper jumper E35 is closed for this configuration.



#### 5.2.1.2 Option 2: Test Points TP3 and TP4

The TB-S3A6 board can also be powered by installing a 5 V power source across TP3 (positive input) and TP4 (negative input). Copper jumper E35 must be opened to enable powering the board using these test points.

**⚠ The on-board Low Dropout Regulator (see section 5.3, Main Components) has an input voltage range of +3.3 V to +5.5 V, and a built-in current limit of 600 mA. Make sure that any external power source connected to TP3 and TP4 meets these requirements.**

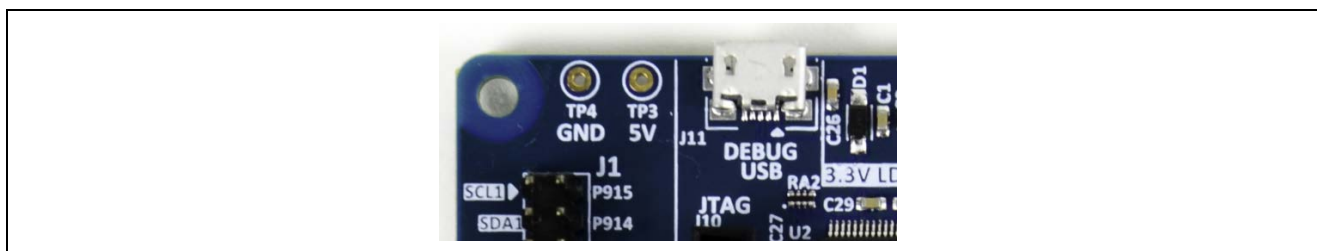

Figure 6. USB Debug Connector (J11), TP3, and TP4 on the Target Board

### 5.2.1.3 Option 3: Test Points TP1 and TP2

The TB-S3A6 board can also be powered by installing a 3.3 V source across TP1 (positive input) and TP2 (negative input). Copper jumper E35 must be open to enable powering the board using these test points.



Figure 7. TP1, TP2, and LED1 on the Target Board



These test points supply voltage directly to the S3A6 MCU, the S124 J-Link MCU, and other on-board circuitry. Use caution to ensure that any voltage connected in this manner meets the power requirements for the active features. Power sources that are outside of the published operating range for the active devices may cause degraded performance or damage the board.

### 5.2.1.4 Option 4: Pin Headers

TB-S3A6 can also be powered through the following pin-headers on the board:

- J1 (pin J1-15 for +3.3 V, pin J1-17 for Return)
- J2 (pin J2-10 for +3.3 V, pin J2-12 for Return)
- J4 (pin J4-37 for +3.3 V, pin J4-36 for Return)

Copper jumper E35 must be open for any of these configurations.



The pin headers supply voltage directly to the S3A6 MCU, the S124 J-Link MCU, and other on-board circuitry. Use caution to ensure that any voltage connected in this manner meets the power requirements for the active features. Power sources that are outside of the published operating range for the active devices may cause degraded performance or damage the board.

See section 5.5, Pin Headers for more information on the Pin Headers.

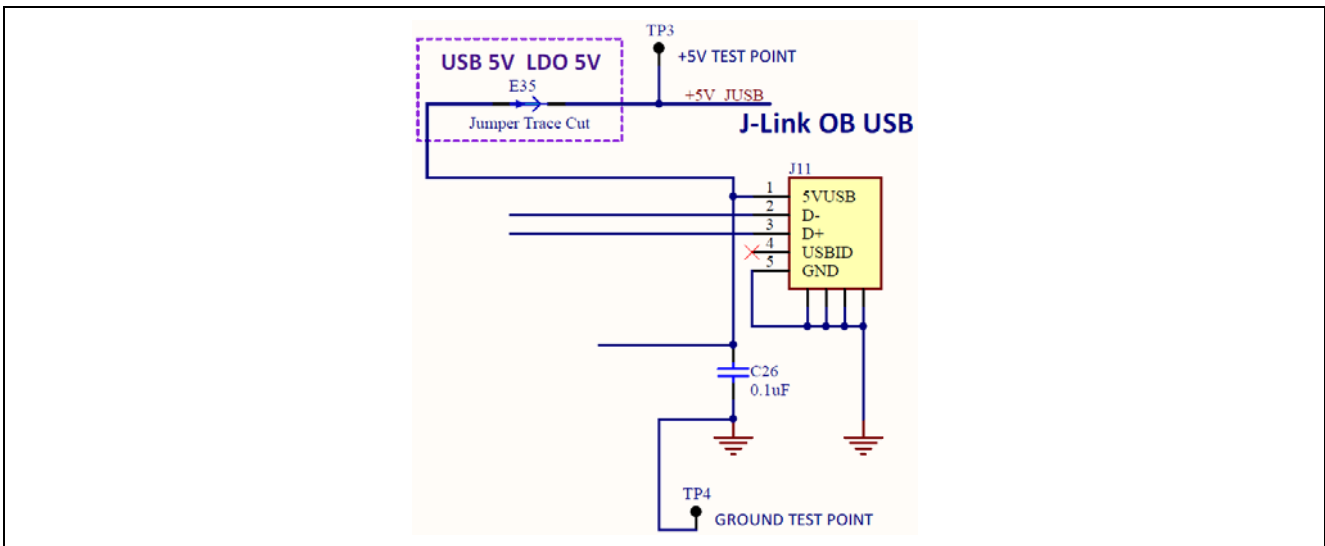

Figure 8. 5 V Power Input Circuit

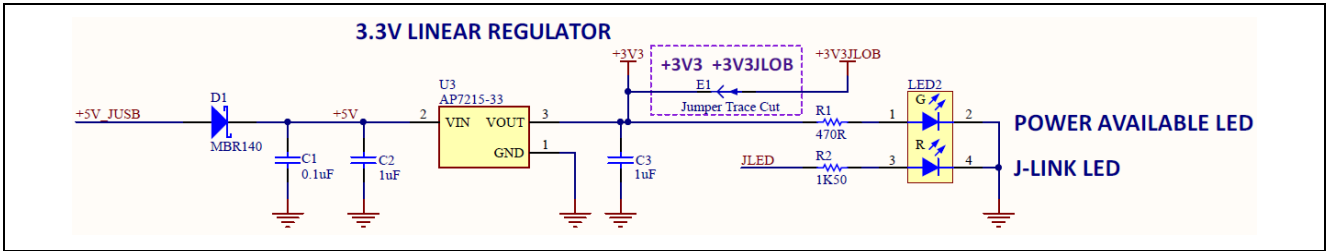

Figure 9. 3.3 V Power Regulator Circuit

**5.2.2 Powering up the Board**

When powered, the green LED to the right of the DEVICE USB connector (LED2) lights up.

The red LED in the same LED package functions as a status indicator for the J-Link® On-board (OB) debug interface on the board. If both LEDs in the LED2 package are lit, LED2 appears orange.

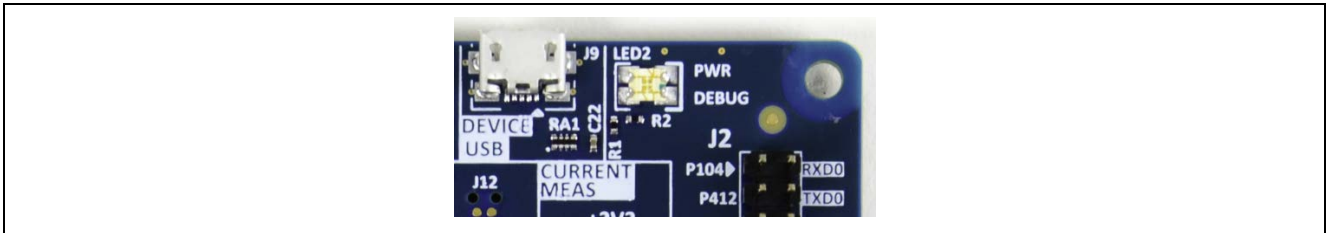

Figure 10. LED2 on the Target Board (Top Side)

**5.2.3 Battery Supply Configuration**

An external battery may be connected according to the methods outlined in section 5.2.1, Power Supply Options, providing that it meets the minimum voltage and current requirements.

Additionally, an external battery source may be connected to VBAT at Pin Header location J2-29 (J2-12 ground return) to maintain the MCU Realtime Clock (RTC) when other main power sources are disconnected from the TB-S3A6 board.

**5.2.4 Measuring Current Consumption**

Pads 1 and 3 of the copper jumper E6, which is a dual trace-cut jumper, allow measurement of +3V3 MCU supply current. Pads 2 and 4 of E6 allow measurement of VBAT supply current. Both traces are connected by default. These traces should be cut to enable power measurement. Care must be taken when cutting the trace to not cause damage to PCB layers below the trace.

The actual current consumed by the S3A6 MCU is dependent on many factors, including ambient temperature, internal clock speed, input voltage level, and device activity. The actual current consumed by the MCU can vary from less than 1 mA to nearly 40 mA. See the *S3A6 Microcontroller Group User's Manual* for more information on the electrical characteristics of the MCU.

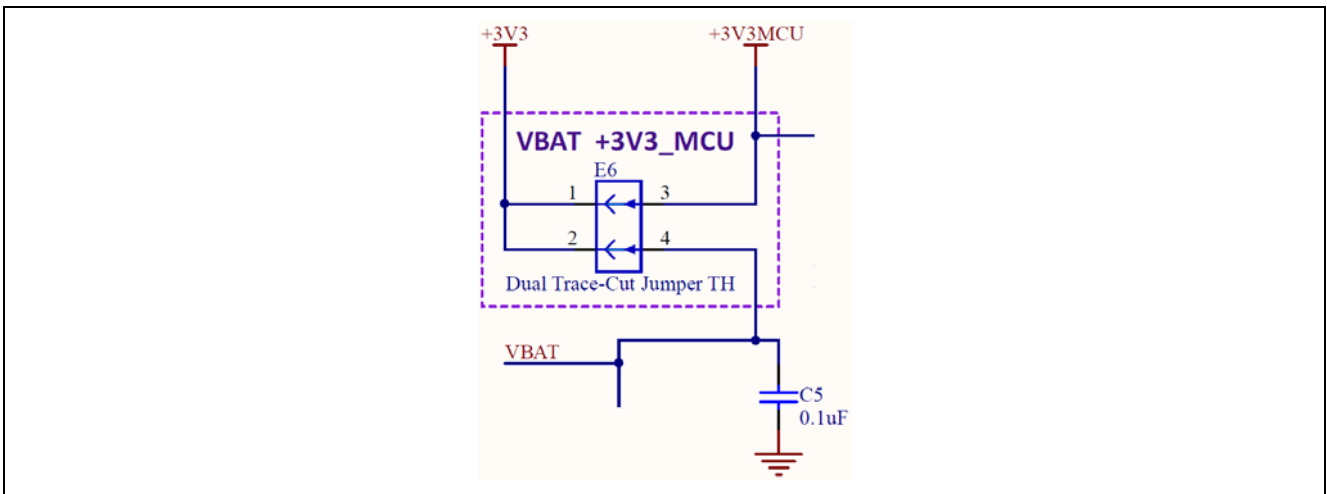

Figure 11. MCU Current Measurement Circuit

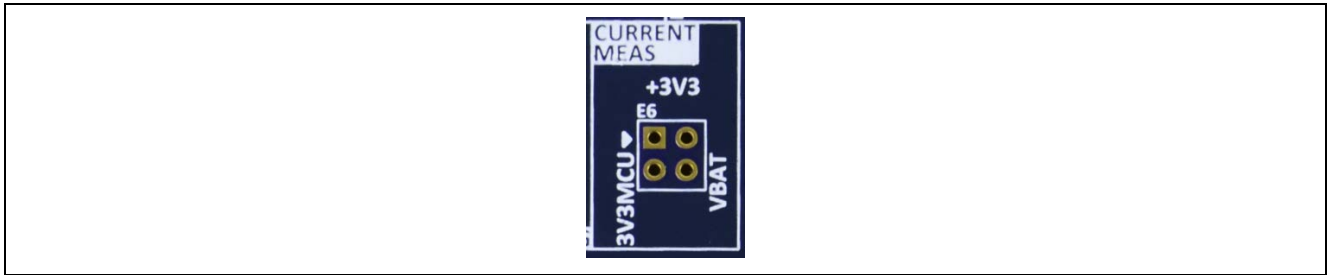

Figure 12. E6 on the Target Board (Top side)



Figure 13. E6 on the Target Board (Bottom side)

Once the shorting traces have been removed, there are several options to measure current:

- Pins can be installed that allow connection of a precision multi-meter or bench meter, or leaded current shunt to allow oscilloscope or data logger connection. When not measuring the current, this allows easily installed and removed shunts to be used to short the jumper terminals.
- Another option is to install current sense resistors between pads 1 and 3 for +3V3 MCU, and between pads 2 and 4 for VBAT. Precision non-inductive film or foil resistors are recommended for use in this application, and the value of each resistor should be carefully considered.

For example, if the expected current requirement for the +3V3 MCU supply voltage is 10 mA, and the user would expect to measure a 10 mV drop across the current measurement resistor, then a 1.0-ohm resistor should be selected and installed.

The actual value selected should be based on the operating conditions of the MCU for the specific user application, and the sensitivity of the measurement equipment used.

### 5.3 Main Components

- Main MCU
  - Renesas Synergy™ S3A6 MCU device, part number R7FS3A6783A01CFP#AA0 (U1)
- J-Link MCU
  - Renesas Synergy™ S124 MCU device, part number R7FS124773A01CFM#AA0 (U2)
- USB Connectors
  - FCI, part number 10118192-0001LF (J9, J11)
    - Micro USB 2.0 Female connector
    - Primary communication with Main MCU and J-Link MCU
- Push-Buttons
  - C&K, part number PTS645SM43SMTR92 LFS (S1, S2)
    - Momentary push-button switch
    - Used for system reset and user defined functions

- LDO Regulator
  - Diodes Inc., part number AP7215-33YG-13 (U3)
    - Low-drop out linear regulator
    - Generates system 3.3 V from J-Link USB 5 V input
- PMOD A Connector
  - Samtec, part number SSW-106-02-F-D-RA (J5)
    - 12-pin right angle connector for PMOD A
- PMOD B Connector
  - Samtec, part number SSW-106-02-FM-S-RA (J6)
    - 6-pin right angle connector for PMOD B
- Pin Headers
  - Sullins, part number PRPC020DAAN-RC (J1, J2, J3, J4)
    - 40 position pin header, 0.1" pitch
    - Provides signal breakout and access for Main MCU signals
- System LED
  - Dialight, part number 598-8610-207F (LED2)
    - Dual color red/green LED
    - System status indicator for power and J-Link status
- User LED
  - Lite-On, part number LTST-C191KRKT (LED1)
    - User defined
    - Single color red LED as needed for user environment
- User Potentiometer
  - Bourns, part number 3352T-1-1-3LF (POT1)
    - User defined
    - Provides variable resistance as needed for user environment

## 5.4 Connectivity and Settings

Throughout this section, feature configuration using copper jumpers is described. See section 4.1.1, Copper Jumpers for information on using copper jumpers.

### 5.4.1 Device USB

The DEVICE USB Micro-B connection jack connects the Main MCU to an external USB Host, FS capable, allowing communications for testing and use of the Main MCU firmware. Power for the Target Board cannot be received from this connector. The DEVICE USB interface can detect the presence of power from the USB Host PC. USB Host power received at the DEVICE USB interface is not connected to the Target Board 5 V power bus.



**Table 2 DEVICE USB Connector (J9)**

USB Device Connector		TB-S3A6
Pin	Description	Signal/Bus
1	+5VDC, connected to a sense voltage 2/3 divider to allow Main MCU sensing of Host presence	+5VUSB P407/USB_VBUS = 2/3(5VUSB)
2	Data-	P915/USB_DM
3	Data+	P914/USB_DP
4	USB ID, jack internal switch, cable inserted	N.C.
5	Ground	GND

Connections in Table 2 are based on the condition of copper jumpers E16, E17, E20, E21, and E30 matching their as-manufactured status. As manufactured, E16 and E17 are closed, E20 and E21 are open, and E30 is closed.



Alternatively, the Device USB signals to the Main MCU may be connected to MCU Pin Header J1. To enable this configuration, copper jumpers E16 and E17 should be open, E20 and E21 should be closed.

### 5.4.2 Debug USB

The DEBUG USB Micro-B connection jack connects the S124 J-Link MCU to an external USB Host, FS capable, allowing re-programming and debugging of the Main MCU firmware. Power for the Target Board may be received from this connector.



The J-Link® OB interface is multiplexed with the JTAG interface, and can collectively be referred to as the Programming Interface. While the J-Link® OB interface and the JTAG interface do not conflict, the J-Link® OB signals may be isolated from the programming interface by changing the associated copper jumpers.

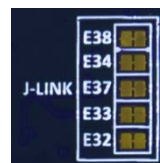

J-Link Disconnect Copper Jumpers E32, E33, E34, E37, and E38, connect the J-Link signals to the MCU programming interface. To isolate the J-Link signals from the JTAG interface, the copper jumpers must be open. To allow use of the J-Link interface, each copper jumper must be closed.

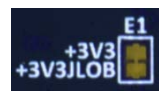

J-Link MCU Power Copper Jumper, E1, connects the main +3.3 V power to the J-Link +3.3 V power. The default condition for E1 is closed, which connects the J-Link MCU power to the main +3.3 V power. If J-Link signals are disconnected, the power to the J-Link MCU should also be removed by changing E1 to open.

**Table 3. DEBUG USB Connector (J11)**

DEBUG USB Connector		TB-S3A6
Pin	Description	Signal/Bus
1	+5VDC	+5V_JUSB
2	Data-	U2 USB_DM (U2-18)
3	Data+	U2 USB_DP (U2-19)
4	USB ID, jack internal switch, cable inserted	N.C.
5	Ground	GND

Three of the J-Link ports (P108, P109, and P300) conflict with the SPI interface, as shown in the following table.

**Table 4. J-Link Interface Conflicts**

Programming Interface		Conflicting Interface	
Port	Use	Interface	Use
P108	SWDIO/JTAG TMS	SPI	SSLB0 fixed function, J1-13
P109	SWO/JTAG TDO	SPI	MOSIB fixed function, J1-7
P300	SWCLK/JTAG TCK	GPT	GTIOC0A fixed function, J1-31

### 5.4.3 JTAG/SWD

A 10-pin Cortex® Debug Connector is provided at J10.

**Table 5. JTAG/SWD Connector (J10)**

JTAG Connector			TB-S3A6
Pin	JTAG pin name	SWD pin name	Signal/Bus
1	VTref	VTref	+3V3
2	TMS	SWDIO	U1 P108/SWDIO (U1-51)

JTAG Connector			TB-S3A6
Pin	JTAG pin name	SWD pin name	Signal/Bus
3	GND	GND	GND
4	TCK	SWCLK	U1 P300/SWCLK (U1-50)
5	GND	GND	GND
6	TDO	SWO	U1 P109 (U1-52)
7	Key	Key	N.C.
8	TDI	NC/EXTb	U1 P110 (U1-53)
9	GNDDetect	GNDDetect	N.C. (short E31 to connect to GND)
10	nSRST	nSRST	U1 RESET# (U1-38)

The Cortex® Debug Connector is fully described in the Arm® CoreSight™ Architecture Specification.

The J-Link MCU Power copper jumper and J-Link Disconnects copper jumpers may be open for proper operation of the JTAG interface to prevent interactions with the J-Link MCU. See section 5.4.2, Debug USB for details.

If a JTAG adapter is in use that properly interprets the Arm® Cortex® 10-pin Debug Connector assignment of pin 9 to GND, the JTAG GNDDetect copper jumper E31 should be closed. If the JTAG adapter used is one of several that may be confused or damaged by the presence of GND at pin 9, E31 should be open (as shipped).

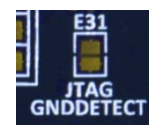

The J-Link® OB interface is multiplexed with the JTAG interface, and can collectively be referred to as the Programming Interface. While the J-Link® OB interface and the JTAG interface do not conflict, the J-Link® OB signals may be isolated from the programming interface by changing the copper jumpers as described in section 5.4.2, Debug USB.

Four of the JTAG ports (P108, P109, P110, and P300) conflict with the SPI interface, as shown in the following table.

**Table 6. JTAG Interface Conflicts**

Programming Interface		Conflicting Interface	
Port	Use	Interface	Use
P108	TMS/J-Link SWDIO	SPI	SSLB0_B fixed function, J1-13
P109	TDO/J-Link SWO	SPI	MOSIB_B fixed function, J1-7
P110	TDI	SPI	MISOB_B fixed function, J1-9
P300	SWCLK	GPT	GTIOC0A_A fixed function, J1-31

### 5.4.4 LEDs

Two LEDs are provided on the TB-S3A6. Target Board U1 is the Main MCU, and directly controls LED1. See Figure 7 for LED1 location, Figure 10 for LED2 location, and Figure 9 for LED2 circuit. Target Board U2 is the J-Link MCU and controls the red LED in LED2.

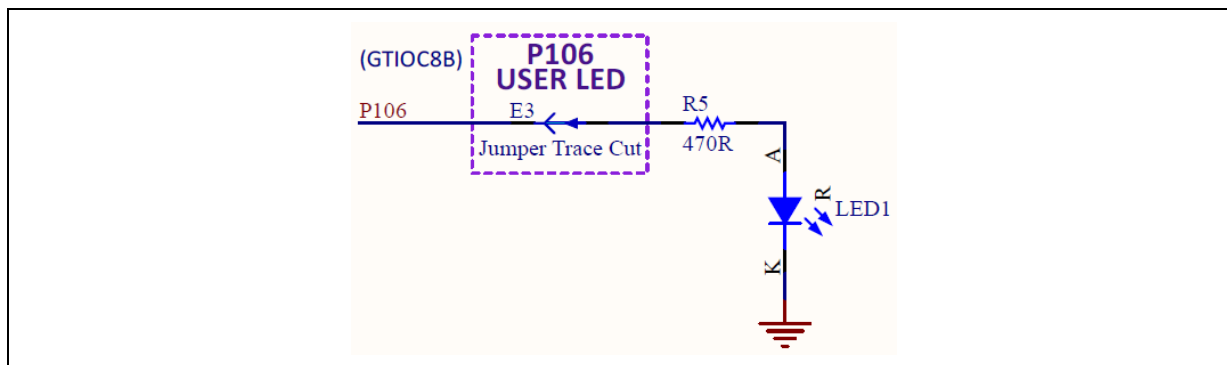

**Figure 14. LED1 Control Circuit**

The behavior of the LEDs is described in the following table.

**Table 7. Target Board LED Functions**

Designator	Color	Function	MCU Control Port	MCU Pin
LED1	Red	User LED	U1 P106	U1-102
LED2	Red	J-Link Indicator	JLED (U2 P103)	U2-45
LED2	Green	3.3 V Power Available	+3V3	N.A.

To disconnect the User LED from the MCU signal P106, the copper jumper E3 must be open.



### 5.4.5 Switches

Two miniature, momentary, mechanical push-button type SMT switches are mounted on the Target Board. Pressing the RESET Switch generates a reset signal to restart the Main MCU.

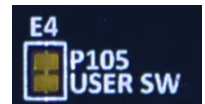

To disconnect the User Switch from the MCU signal P105/IRQ0, copper jumper E4 must be open.

**Table 8. Target Board Switches**

Designator	Function	MCU Control Port	MCU Pin
S1	User Switch	U1 P105/IRQ0	U1-103
S2	MCU Reset Switch	RESET#	U1-55

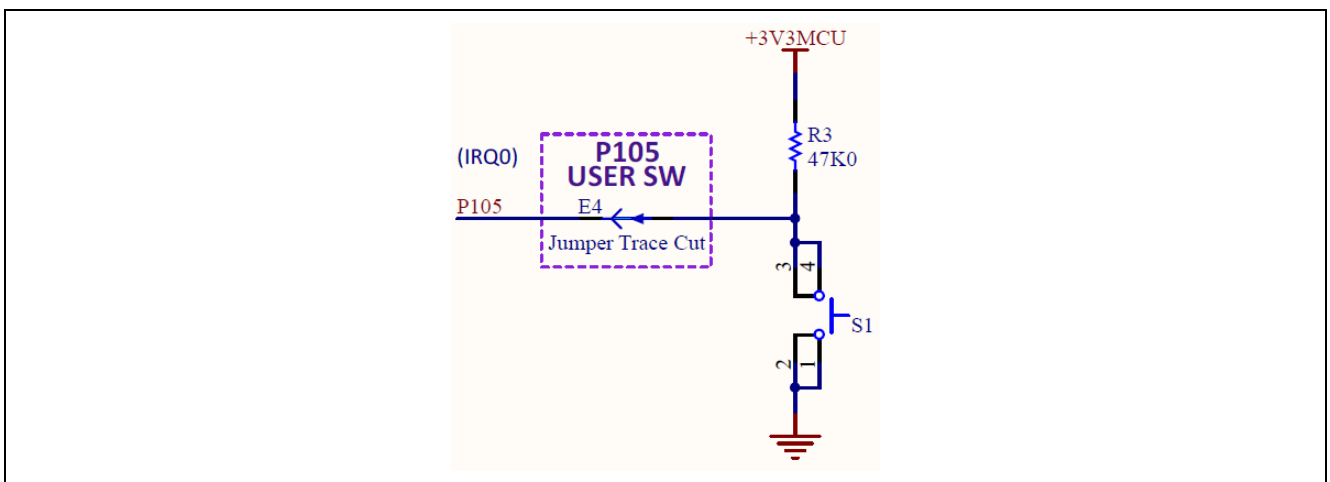

**Figure 15. User Switch Circuit**



**Figure 16. User Switch (S1) on the Target Board**

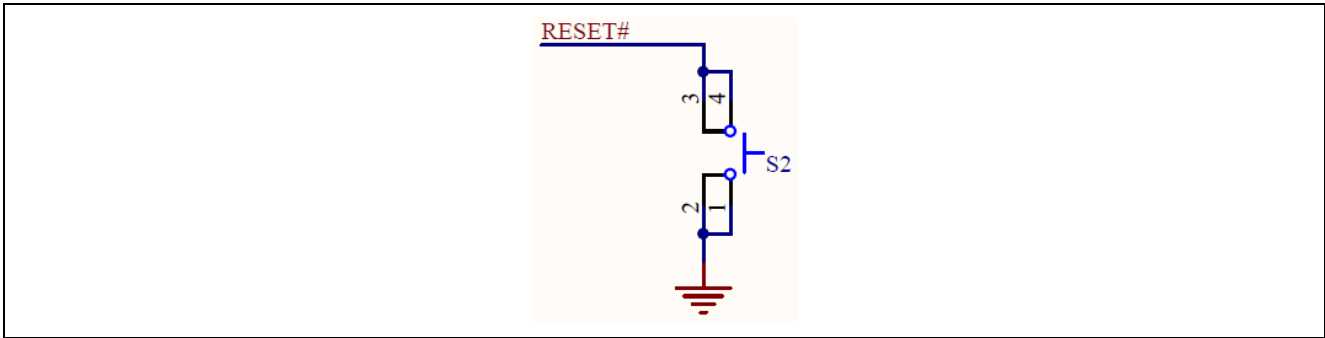

Figure 17. Reset Switch Circuit

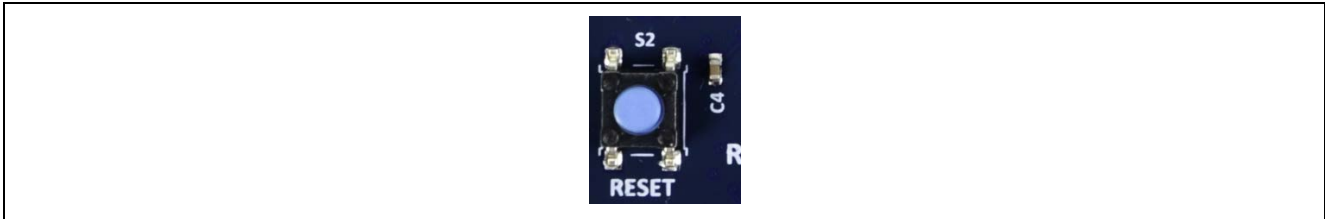

Figure 18. Reset Switch (S2) on the Target Board

**5.4.6 PMOD A**

A 12-pin PMOD type 2A connector is provided at PMOD A. The interface is powered for 3.3 V modules only. The Main MCU acts as the SPI master, and the connected module acts as an SPI slave device. This interface may additionally be re-configured in firmware as several other PMOD types.

Signals on PMOD A are shared with Main MCU pin headers J1 and J2. Care must be taken to ensure that shared signals are not used concurrently.



Table 9. PMOD A Connector (J5)

USB Device Connector		TB-S3A6
Pin	Description	Signal/Bus
1	SS (low to select slave)	U1 P103, SSLA0_A (U1-72)
2	MOSI	U1 P101, MOSIA_A (U1-74)
3	MISO	U1 P100, MISOA_A (U1-75)
4	SCK	U1 P102, RSPCKA_A (U1-73)
5	GND	GND
6	VCC	+3V3
7	INT (slave to master)	U1 P104, IRQ1 (U1-71)
8	RESET (master to slave)	U1 P107, GPIO (U1-68)
9	Not Specified	U1 P111, GPIO (U1-54)
10	Not Specified	U1 P112, GPIO (U1-55)
11	GND	GND
12	VCC	+3V3

Limits of the 3.3 V regulator on the Target Board, and limits of the power source supplying that regulator (especially for USB Host devices), including the to-be-connected PMOD device, must be considered prior to connecting a module to a PMOD connector.

### 5.4.7 PMOD B

A 6-pin PMOD type 4 connector is provided at PMOD B. The interface is powered for 3.3 V modules only. The Main MCU acts as the UART DCE, and the connected module acts as the UART DTE. This interface may additionally be re-configured in firmware as some other PMOD type.

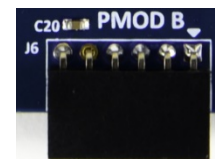

Signals on PMOD B are shared with Main MCU pin header J1 and J2. Care must be taken to ensure that shared signals are not used concurrently.

**Table 10. PMOD B Connector (J6)**

USB Device Connector		TB-S3A6
Pin	Description	Signal/Bus
1	CTS (from module)	U1 P403, CTS1 (U1-4)
2	TXD	U1 P401, TXD1 (U1-2)
3	RXD	U1 P402, RXD1 (U1-3)
4	RTS (from Main MCU)	U1 P400, GPIO (U1-1) (for RTS by Main MCU firmware)
5	GND	GND
6	VCC	+3V3

Limits of the 3.3 V regulator on the Target Board, and limits of the power source supplying that regulator (especially for USB Host devices), including the to-be-connected PMOD device, must be considered prior to connecting a module to a PMOD connector.

### 5.4.8 User Capacitive Touch Button

A capacitive sensor region for use as a Capacitive Touch button is provided in the board USER INPUT region. A support circuit, TSCAP, is required for proper operation of Capacitive Touch button(s) by the Main MCU.

To disconnect the Capacitive Touch Button from the MCU, the copper jumper E2 must be open.

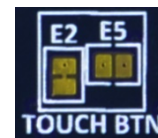

To connect MCU signal P115 to Pin Header J3, the copper jumper E5 must be closed.

**Table 11. Target Board Capacitive Touch Button Sensor**

Designator	Function	MCU Control Port	MCU Pin
TS1	Capacitive Touch Button	U1 P115 (TS35)	U1-80
-	TSCAP Support	U1 P205 (TSCAP-A)	U1-43

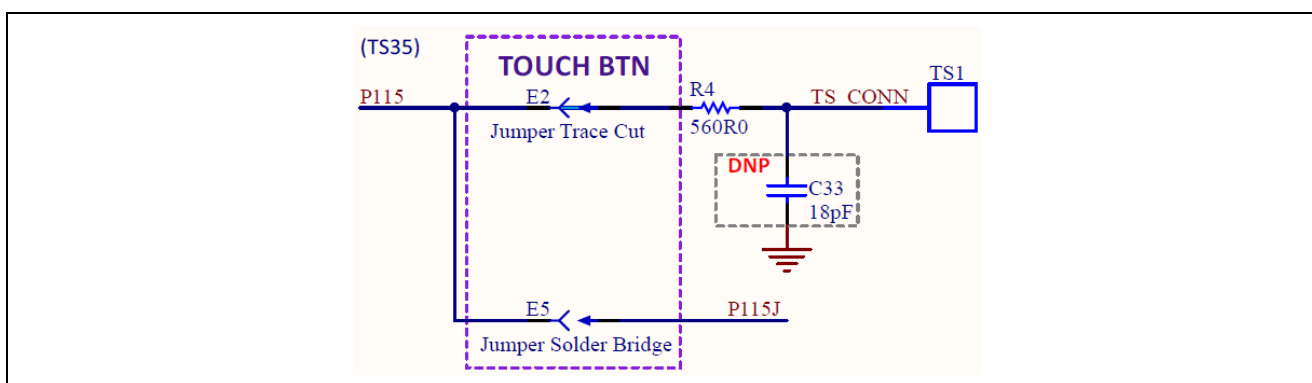

**Figure 19. Capacitive Touch-Button Circuit**

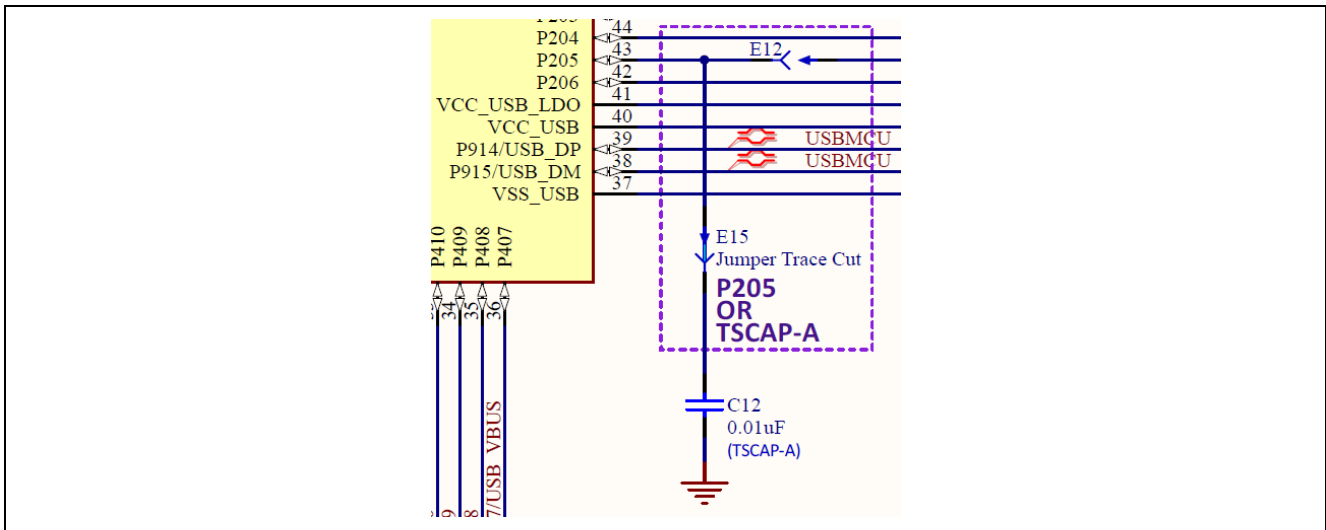

Figure 20. Capacitive Touch TSCAP Circuit



Figure 21. Capacitive Touch Button On the Target Board (Top side)

### 5.5 Pin Headers

The Target Board Pin Headers, J1, J2, J3, and J4, provide access to all Main MCU interface signals, and to voltages for all Main MCU power ports.

#### Fixed Function Pin Assignments

For consistency across all Synergy Target Board Kits, some pin assignments on the headers have **fixed function** signal assignments. This provides specific signals and functions to be at a common pin header location on all Target Boards for S1, S3, S5, S7 Synergy MCU Series.

On the TB-S3A6, 40 pins of the pin headers are set aside for **fixed function** assignment. These pins are odd-numbered pins of J1 and even-numbered pins of J2.

Pin Header Fixed Function Pins are labeled on the Target Board with dark text on a white background. Pins that are not Fixed Function pins are labeled with white text on a dark background. On the top side of the board is the functional label for the fixed location. On the bottom side of the board is the port information for the same pin.

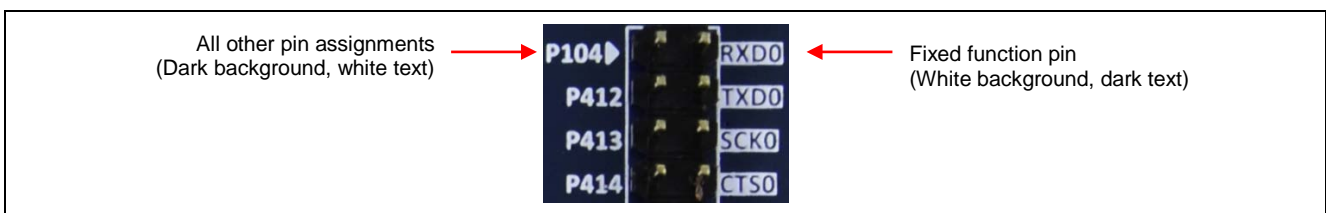

Figure 22. Fixed Function Pin Label Example

There are several pins in the headers that are **secondary fixed function** pins. These secondary fixed function pins share common pin assignments with other Target Boards that have Main MCUs with the same functionality. The secondary fixed function pins are also labeled with the top side having a functional label, and bottom side having a port label.

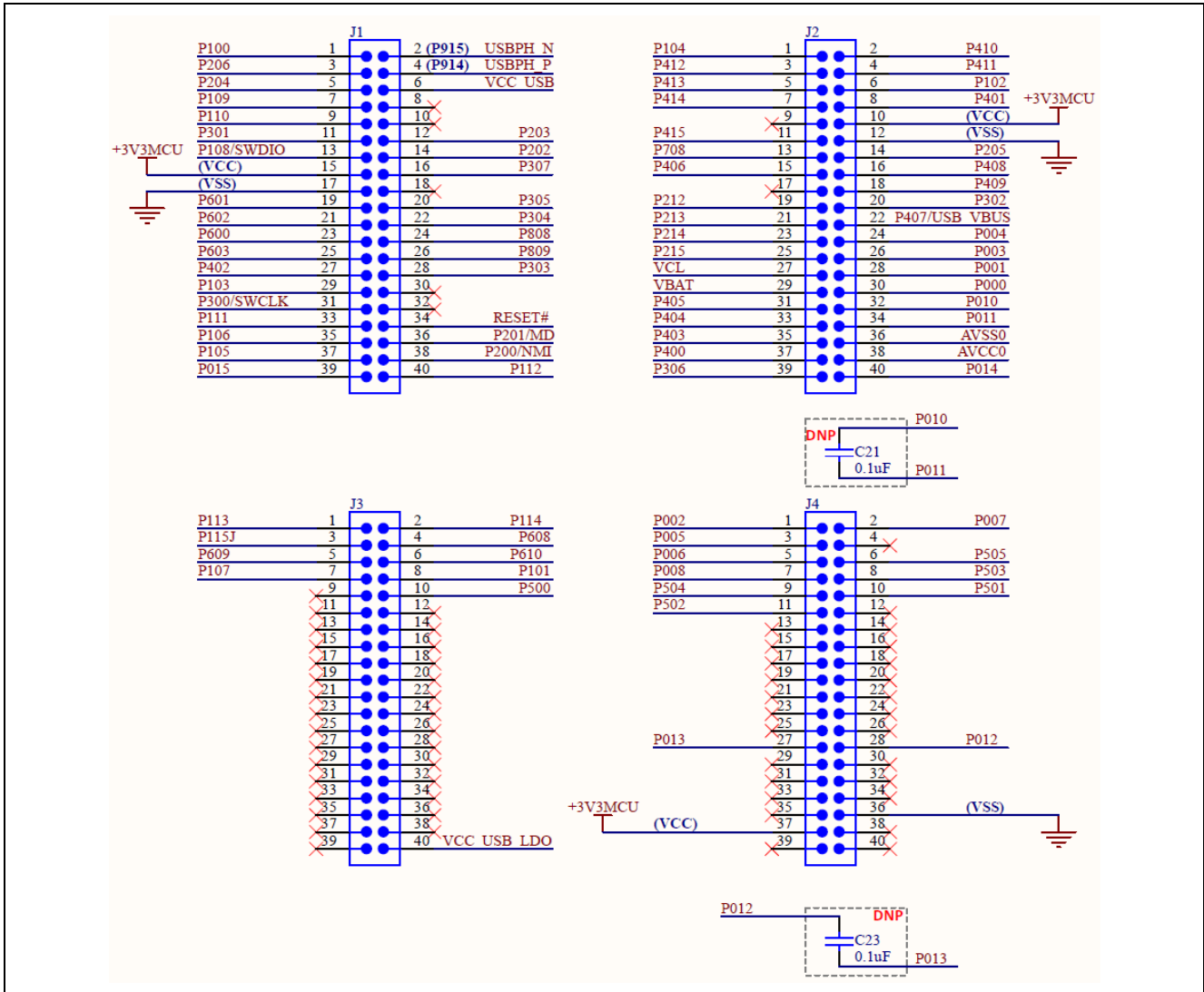

Figure 23. Pin Headers Circuits

### 5.5.1 Pin Header J1

Pin Header J1 is a 2-column by 20-row through-hole pin header on 2.54 mm centers.

**Table 12. Pin Header J1 Pin Assignment**

100p S3A6 Pin	S3A6 Signal	J1 Pins		S3A6 Signal	100p S3A6 Pin
75	P100	1	2	P914/USB_DP	28
31	P206	3	4	P915/USB_DM	27
33	P204	5	6	VCC_USB	29
52	P109/TDO/SWO	7	8	(None)	NC
53	P110/TDI	9	10	(None)	NC
49	P301	11	12	P203	34
51	P108/TMS/SWDIO	13	14	P202	35
62	VCC	15	16	P307	41
63	VSS	17	18	(None)	NC
66	P601	19	20	P305	43
65	P602	21	22	P304	44
67	P600	23	24	P808	45
64	P603	25	26	P809	46
3	P402	27	28	P303	47
72	P103	29	30	(None)	NC
50	P300/TCK/SWCLK	31	32	(None)	NC
54	P111	33	34	RES	38
69	P106	35	36	P201/MD	39
70	P105	37	38	P200	40
84	P015	39	40	P112	55

#### Color Key

Primary Fixed Function Pins
Secondary Fixed Function Pins

**5.5.2 Pin Header J2**

Pin Header J2 is a 2-column by 20-row through-hole pin header on 2.54 mm centers.

**Table 13. Pin Header J2 Pin Assignment**

100p S3A6 Pin	S3A6 Signal	J2 Pins		S3A6 Signal	100p S3A6 Pin
71	P104	1	2	P410	22
20	P412	3	4	P411	21
19	P413	5	6	P102	73
18	P414	7	8	P401	2
NC	(None)	9	10	VCC	15
17	P415	11	12	VSS	12
16	P708	13	14	P205	32
7	P406	15	16	P408	24
NC	(None)	17	18	P409	23
14	P212/EXTAL	19	20	P302	48
13	P213/XTAL	21	22	P407	25
11	P214/XCOUT	23	24	P004	96
10	P215/XCIN	25	26	P003	97
9	VCL	27	28	P001	99
8	VBATT	29	30	P000	100
6	P405	31	32	P010/VREFH0	91
5	P404	33	34	P011/VREFL0	90
4	P403	35	36	AVSS0	89
1	P400	37	38	AVCC0	88
42	P306	39	40	P014	85

Color Key

Primary Fixed Function pins
Secondary Fixed Function pins

**5.5.3 Pin Header J3**

Pin Header J3 is a 2-column by 20-row through-hole pin header on 2.54 mm centers.

**Table 14. Pin Header J3 Pin Assignment**

100p S3A6 Pin	S3A6 Signal	J3 Pins		S3A6 Signal	100p S3A6 Pin
56	P113	1	2	P114	57
58	P115	3	4	P608	59
60	P609	5	6	P610	61
68	P107	7	8	P101	74
NC	(None)	9	10	P500	76
NC	(None)	11	12	(None)	NC
NC	(None)	13	14	(None)	NC
NC	(None)	15	16	(None)	NC
NC	(None)	17	18	(None)	NC
NC	(None)	19	20	(None)	NC
NC	(None)	21	22	(None)	NC
NC	(None)	23	24	(None)	NC
NC	(None)	25	26	(None)	NC
NC	(None)	27	28	(None)	NC
NC	(None)	29	30	(None)	NC
NC	(None)	31	32	(None)	NC
NC	(None)	33	34	(None)	NC
NC	(None)	35	36	(None)	NC
NC	(None)	37	38	(None)	NC
NC	(None)	39	40	VCC_USB_LDO	30

Color Key

Secondary Fixed Function pins
-------------------------------

### 5.5.4 Pin Header J4

Pin Header J4 is a 2-column by 20-row through-hole pin header on 2.54 mm centers.

**Table 15. Pin Header J4 Pin Assignment**

100p S3A6 Pin	S3A6 Signal	J4 Pins		S3A6 Signal	100p S3A6 Pin
98	P002	1	2	P007	93
95	P005	3	4	(None)	NC
94	P006	5	6	P505	81
92	P008	7	8	P503	79
80	P504	9	10	P501	77
78	P502	11	12	(None)	NC
NC	(None)	13	14	(None)	NC
NC	(None)	15	16	(None)	NC
NC	(None)	17	18	(None)	NC
NC	(None)	19	20	(None)	NC
NC	(None)	21	22	(None)	NC
NC	(None)	23	24	(None)	NC
NC	(None)	25	26	(None)	NC
87	P012/VREFH	27	28	P013/VREFL	86
NC	(None)	29	30	(None)	NC
NC	(None)	31	32	(None)	NC
NC	(None)	33	34	(None)	NC
NC	(None)	35	36	VSS	12
15	VCC	37	38	(None)	NC
NC	(None)	39	40	(None)	NC

Color Key

Secondary Fixed Function pins
-------------------------------

## 5.6 Additional Features

### 5.6.1 Analog Reference Voltages

A footprint for installation of capacitors C21 and C23 is provided on the Target Board. These two capacitors provide noise-bypass capability for ports P010/P011 and for ports P012/P013. See Figure 23 for the circuit design.

Port pair P010/P011 may be assigned as GPIO, where bypass capacitor C21 would damage signal quality. When P010/P011 are to be assigned as VREFH0/VREFL0, installation of the capacitor C21 can reduce reference voltage noise and improve ADC measurement and DAC output quality. The Target Board was designed for Samsung P/N CL10B104KB8NANC, or similar, noise-bypass capacitors.

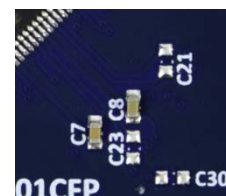

Port pair P012/P013 may be assigned as GPIO, where bypass capacitor C23 would damage signal quality. When P012/P013 are to be assigned as VREFH/VREFL, installation of capacitor C23 may reduce reference voltage noise and improve ADC measurement and DAC output quality. The Target Board was designed for Samsung P/N CL10B104KB8NANC, or similar noise-bypass capacitors.

### 5.6.2 On-Board Clock Crystals

The TB-S3A6 includes two precision crystal clock sources. A precision 12.000 MHz crystal is installed at location X1, and a precision 32.768 kHz crystal is installed at location X2. These crystal clock sources are connected to the Main MCU by default.

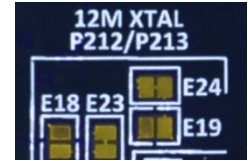

The MCU pins for the 12 MHz clock crystal may be connected to P212 and P213. To disconnect the 12 MHz crystal, open copper jumpers E23 and E24, and close copper jumpers E18 and E19.

The MCU pins for the 32.768 kHz clock crystal may be connected to P214 and P215. To disconnect the 32.768 kHz crystal, open copper jumpers E25 and E26, and close copper jumpers E22 and E27.

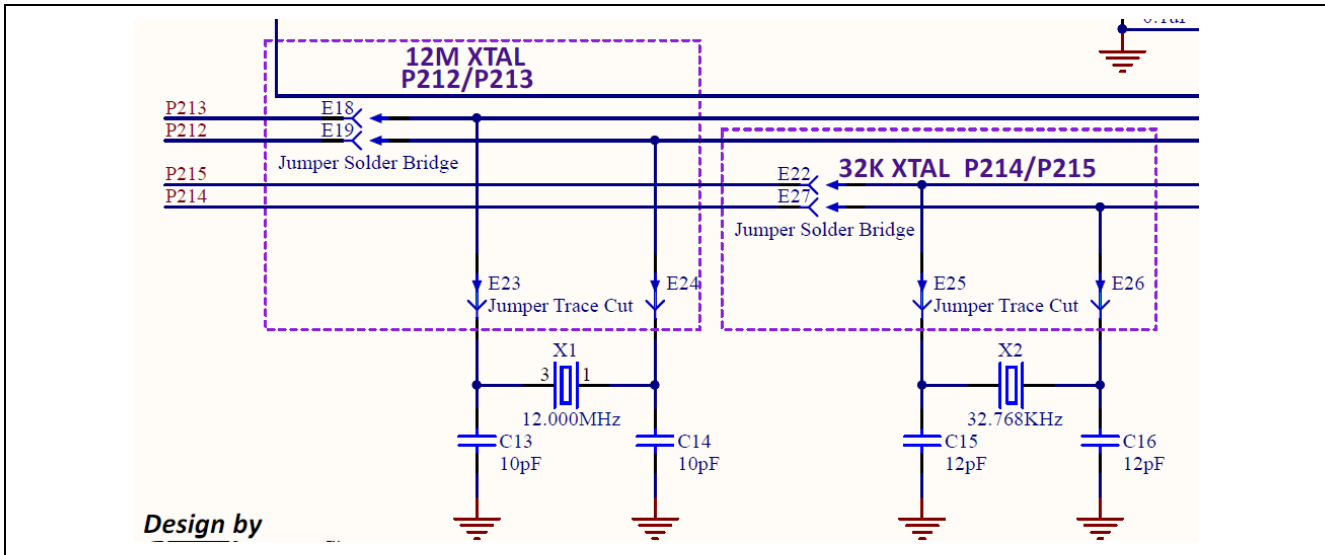

Figure 24. Crystal Clock Sources

### 5.6.3 User Potentiometer

A footprint for installation of a potentiometer and a recommended noise-bypass capacitor are provided on the Target Board. The footprint was designed for installation of a Bourns P/N 3352T-1-103LF, or equivalent, as the potentiometer, and a Samsung P/N CL10B104KB8NNNC, or similar, as the noise-bypass capacitor.

When the User Potentiometer is installed, copper jumper E36 must be closed to connect the User Potentiometer to the MCU.

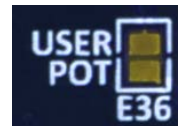

Table 16. Target Board User Potentiometer

Designator	Function	MCU Control Port	MCU Pin
POT1	User Potentiometer	U1 P004 (AN004)	U1-136

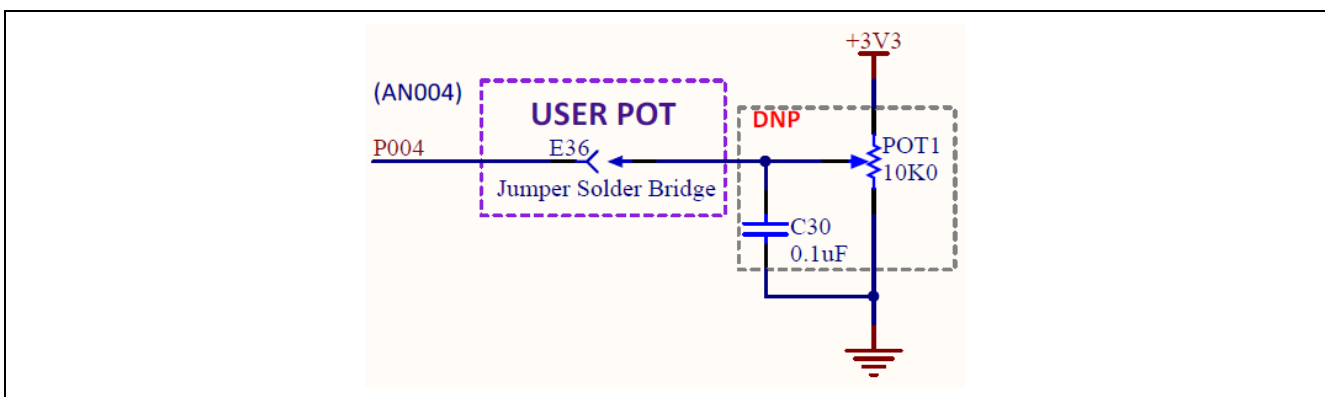

Figure 25. User Potentiometer Circuit

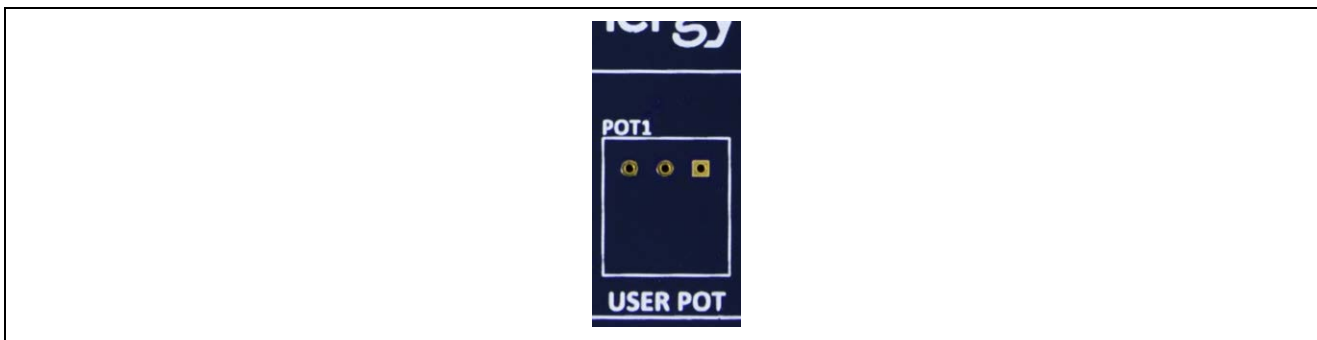

Figure 26. User Potentiometer on the Target Board (top)

### 5.6.4 Boot Configuration

The BOOT CONFIG jumper, J8 is used to configure the operating mode of the S3A6 MCU at boot.

Table 17. Boot Configuration

Boot Configuration	J8 Shunt Location
Normal Boot (default)	Pins 1 and 2
SCI / USB Boot	Pins 1 and 3

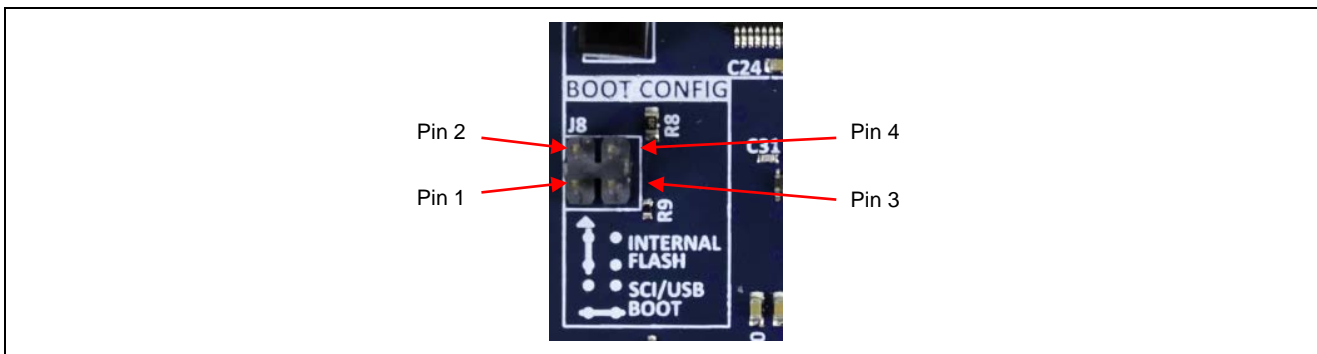

Figure 27. Boot Configuration Jumper J8

### 5.6.5 Miscellaneous Signals

#### 5.6.5.1 AVCC0/AVSS0

By default, AVCC0 is connected to +3V3 MCU and AVSS0 is connected to the system ground. To disconnect these references from the AVCC0 and AVSS0 lines, copper jumpers E10 and E11 must be open.



#### 5.6.5.2 VCL

By default, the Main MCU pin VCL is connected to reference capacitor C17. To connect this pin to the MCU pin header J2, solder bridge E28 must be closed. To disconnect the reference capacitor C17, copper jumper E29 must be open.



#### 5.6.5.3 VCC\_USB\_LDO

By default, the Main MCU pin VCC\_USB\_LDO is connected to the +3V3 MCU supply voltage. Alternatively, this pin may be connected to MCU pin header J3. To do this, copper jumper E7 must be open and copper jumper E13 must be closed.



#### 5.6.5.4 VCC\_USB

By default, the Main MCU pin VCC\_USB is connected to the +3V3 MCU supply voltage. Alternatively, this pin may be connected to MCU pin header J1. To do this, the copper jumper E8 must be open and the copper jumper E14 must be closed.

### 5.6.5.5 Signal P205

By default, the Main MCU pin P205 is connected to a TSCAP-A capacitor. This pin may be connected to the MCU Pin Header J2. To do this, the copper jumper E12 must be closed. The TSCAP-A capacitor may be disconnected by making the copper jumper E15 open.

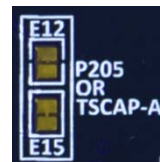

6. Electrical Schematics

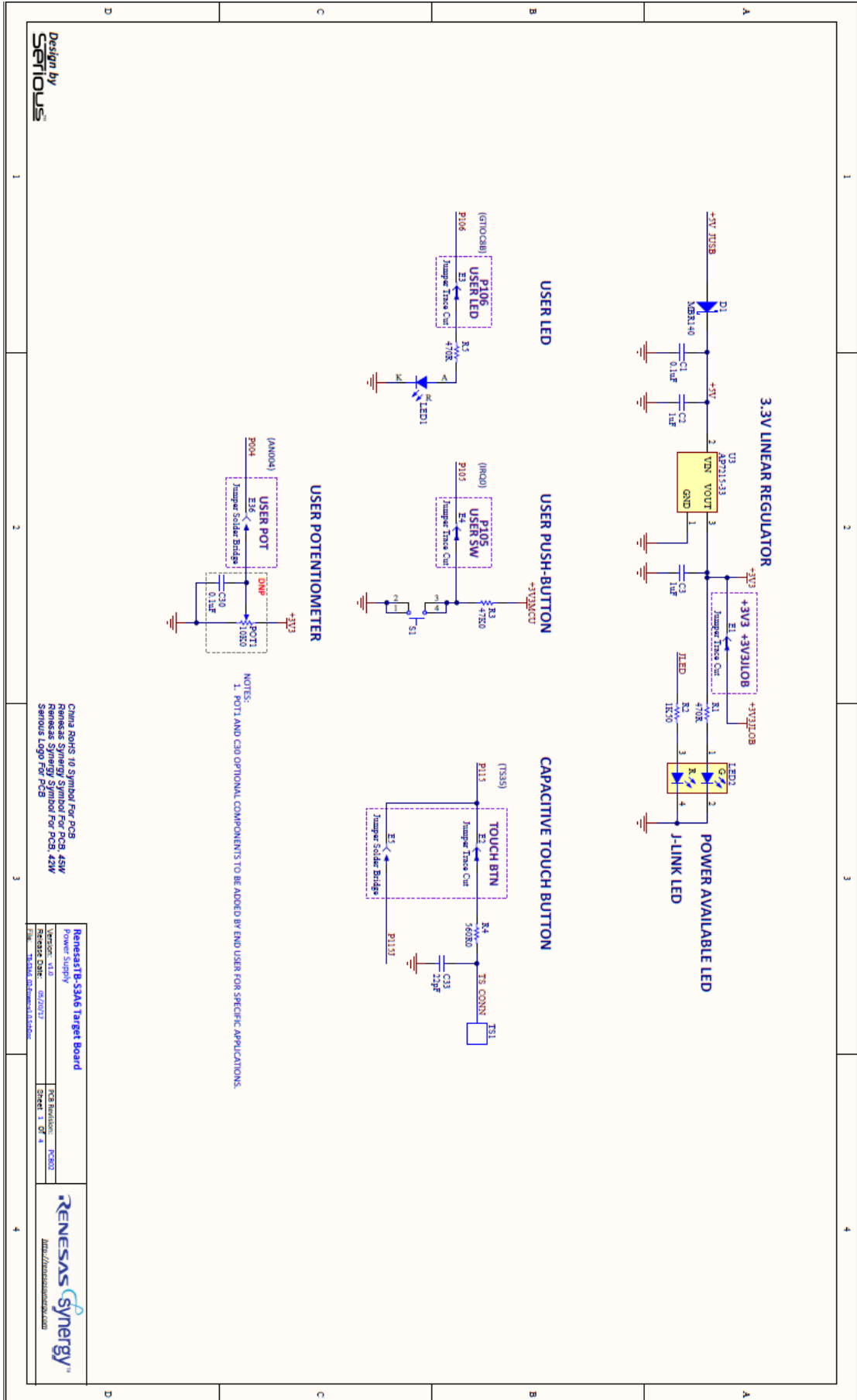

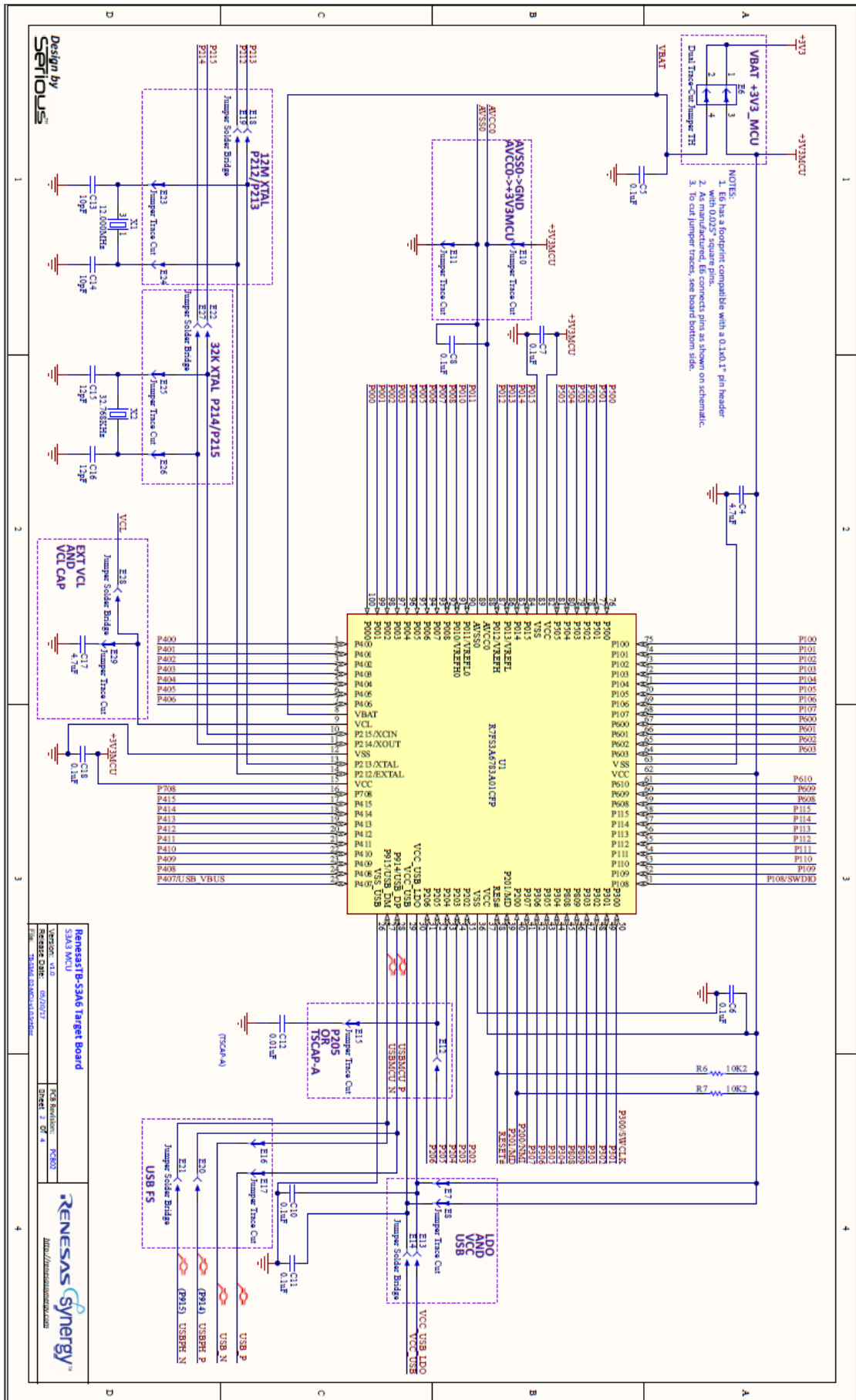



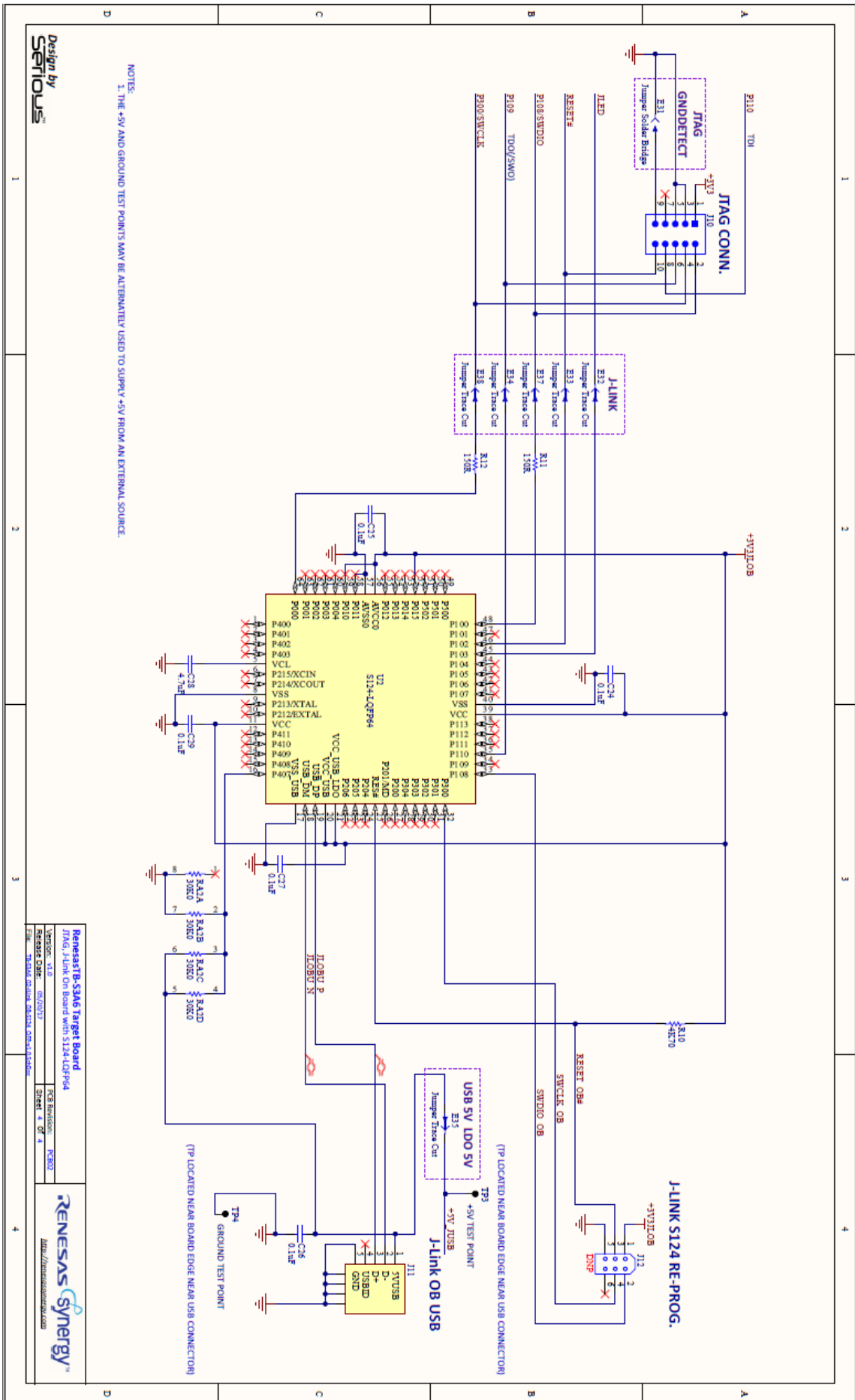

7. Mechanical Drawing

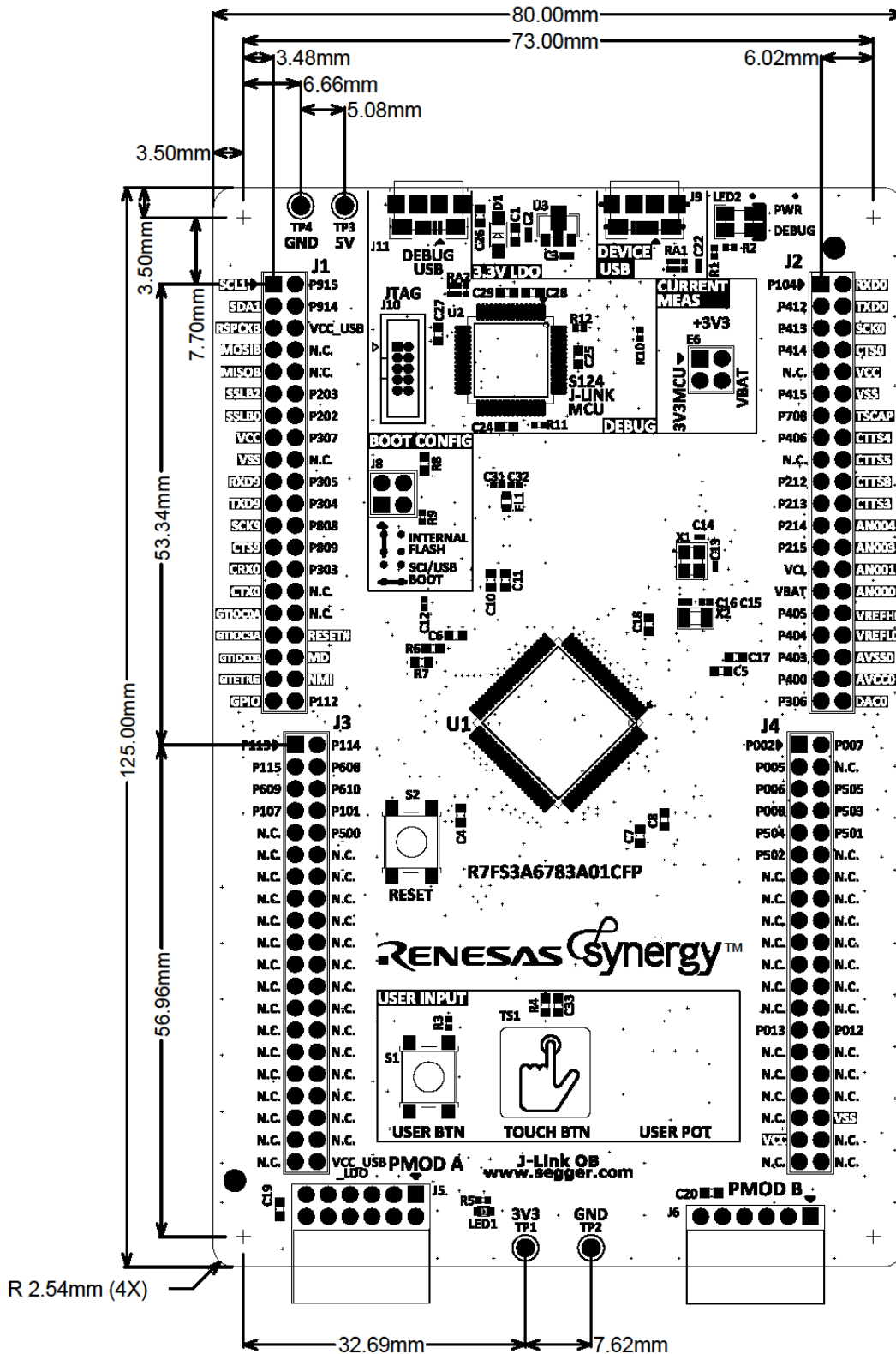

**Table 18. Target Board Physical Characteristics and Locations**

Parameter	Value	Units
Target Board Envelope Height	130	mm
Target Board Envelope Width	80	mm
Target Board Envelope Thickness, including solder mask, not including overlay printing	11	mm
Target Board assembled weight (estimated)	65	grams
Target Board shipping weight	TBD	grams
Target Board PCB Height	125	mm
Target Board PCB Width	80	mm
Target Board PCB Thickness, including solder mask, not including overlay printing	1.65	mm
PCB corner rounding radius	2.54	mm
Mounting holes' diameter	3.175	mm
Mounting Hole Upper Left (center)	(3.5,121.5)	mm
Mounting Hole Lower Left (center)	(3.5,3.5)	mm
Mounting Hole Upper Right (center)	(76.5,121.5)	mm
Mounting Hole Lower Right (center)	(76.5,3.5)	mm
J1 (Upper Left pin header, locate pin 1)	(6.98,113.8)	mm
J2 (Upper Right pin header, locate pin 1)	(70.48,113.8)	mm
J3 (Lower Left pin header, locate pin 1)	(9.52,60.46)	mm
J4 (Lower Right pin header, locate pin 1)	(67.94,60.46)	mm
TP1 (3V3, center)	(36.19,2.215)	mm
TP2 (GND, center)	(43.81,2.215)	mm
TP3 (5V, center)	(15.235,122.865)	mm
TP4 (GND, center)	(10.155,122.865)	mm
PMOD A (12-pin Female right-angle, locate pin 1)	(23.49,8.39)	mm
PMOD B (6-pin Female right-angle, locate pin 1)	(69.21,5.85)	mm

**Notes:**

- Envelope size is the enveloping box inner dimensions for the assembled Target Board with pin headers, USB micro-B connectors and PMOD connectors installed.
- Position is shown as (#,#), where the first number is distance from the left Target Board edge and the second number is distance from the lower Target Board edge (board viewed with **Renesas** oriented for normal viewing), board viewed from its top surface.

**8. Certifications****FCC Compliance**

This device complies with part 15 of the FCC Rules. Operation is subject to the following two conditions: (1) This device may not cause harmful interference, and (2) This device must accept any interference received, including interference that may cause undesired operation.

**China SJ/T 113642014, 10 year environmental protection use period.**

**EU RoHS****EU EMI/EMC Compliance**

## Website and Support

Visit the following vanity URLs to learn about key elements of the Synergy Platform, download components and related documentation, and get support.

Synergy Software	<a href="http://www.renesas.com/synergy/software">www.renesas.com/synergy/software</a>
Synergy Software Package	<a href="http://www.renesas.com/synergy/ssp">www.renesas.com/synergy/ssp</a>
Software add-ons	<a href="http://www.renesas.com/synergy/addons">www.renesas.com/synergy/addons</a>
Software glossary	<a href="http://www.renesas.com/synergy/softwareglossary">www.renesas.com/synergy/softwareglossary</a>
Development tools	<a href="http://www.renesas.com/synergy/tools">www.renesas.com/synergy/tools</a>
Synergy Hardware	<a href="http://www.renesas.com/synergy/hardware">www.renesas.com/synergy/hardware</a>
Microcontrollers	<a href="http://www.renesas.com/synergy/mcus">www.renesas.com/synergy/mcus</a>
MCU glossary	<a href="http://www.renesas.com/synergy/mcuglossary">www.renesas.com/synergy/mcuglossary</a>
Parametric search	<a href="http://www.renesas.com/synergy/parametric">www.renesas.com/synergy/parametric</a>
Kits	<a href="http://www.renesas.com/synergy/kits">www.renesas.com/synergy/kits</a>
Synergy Solutions Gallery	<a href="http://www.renesas.com/synergy/solutionsgallery">www.renesas.com/synergy/solutionsgallery</a>
Partner projects	<a href="http://www.renesas.com/synergy/partnerprojects">www.renesas.com/synergy/partnerprojects</a>
Application projects	<a href="http://www.renesas.com/synergy/applicationprojects">www.renesas.com/synergy/applicationprojects</a>
Self-service support resources:	
Documentation	<a href="http://www.renesas.com/synergy/docs">www.renesas.com/synergy/docs</a>
Knowledgebase	<a href="http://www.renesas.com/synergy/knowledgebase">www.renesas.com/synergy/knowledgebase</a>
Forums	<a href="http://www.renesas.com/synergy/forum">www.renesas.com/synergy/forum</a>
Training	<a href="http://www.renesas.com/synergy/training">www.renesas.com/synergy/training</a>
Videos	<a href="http://www.renesas.com/synergy/videos">www.renesas.com/synergy/videos</a>
Chat and web ticket	<a href="http://www.renesas.com/synergy/resourcelibrary">www.renesas.com/synergy/resourcelibrary</a>

**Revision History**

Rev.	Date	Description	
		Page	Summary
1.00	Aug.23.17	-	Initial release
1.01	Dec.18.17	-	Replaced the graphics
1.02	Jul.10.19	-	Corrected a typo for package type

---

Target Board Kit S3A6 (TB-S3A6) User's Manual

Publication Date: Jul.10.19

Published by: Renesas Electronics Corporation

---

# Renesas Synergy™ Platform Target Board Kit S3A6 (TB-S3A6)